

SEGA®

甲虫王者 MUSAIKING

The King of Beetle

U.S. & U.K. Version
Owner's Manual



SEGA AMUSEMENTS USA, INC.

MANUAL NO. 999-2187

GAME CODE: MKG

VISIT OUR WEBSITE!

SEGA SERVICE Sega Amusements USA Inc.
45133 Industrial Dr.
Fremont, CA 94538
(415) 701-6580

Google™ Search SEUService.com Site Search

Home	Whats New	Manuals	Bulletins	Assemblies	Graphics	
Search	Bulletin Sign-Up	Staff		Warranty Policy	Return Policy	Corporate Info

The NEW I/R Gun Protect Bd !!



(Click here for details)

SEGA SERVICE

- Bulletins
- Game Manuals
- Search
- What's New

If you have any questions or comments about this site please E-Mail to Dave.Cantrelle@seu.sega.com



Now with a new look to make your experience that much easier.

HARD CANDY
ハードキャンデー
WWW.HARD-CANDY.COM

BEFORE USING THE PRODUCT, BE SURE TO READ THE FOLLOWING:

To maintain the safety:

To ensure the safe usage of the product, be sure to read the following before using the product. The following instructions are intended for the users, operators and the personnel in charge of the operation of the product. After carefully reading and sufficiently understanding the warning displays and cautions, handle the product appropriately. Be sure to keep this manual nearby the product or elsewhere convenient for referring to it when necessary.

Herein, explanations which require special attention are enclosed with dual lines. Depending on the potentially hazardous degrees, the terms of WARNING, CAUTION, etc. are used. Be sure to understand the contents of the displays before reading the text.



Indicates that mishandling the product by disregarding this warning will cause a potentially hazardous situation which can result in death or serious injury.



Indicates that mishandling the product by disregarding this caution will cause a slight hazardous situation which can result in personal injury and or material damage.

For the safe usage of the product, the following pictographs are used:



Indicates "HANDLE WITH CARE." In order to protect the human body an equipment, this display is attached to places where the Owner's Manual and or Service Manual should be referred to.



Indicates a "Protective Earth Terminal." Before operating the equipment, be sure to connect it to the Ground. (Except the product with which the power cord with earth is used.)

○ Perform work in accordance with the instructions herein stated.

Instructions for work are explained by paying attention to the aspect of accident prevention. Failing to perform work as per the instructions can cause accidents. In the case where only those who have technical expertise should perform the work to avoid hazardous situation, the instructions herein state that the serviceman should perform such work.

○ Be sure to turn off power before working on the machine.

To prevent electric shock, be sure to turn off power before starting the work in which the worker touches the interior of the product. If the work is to be performed in the power-on status, the Instruction Manual herein always states to that effect.

○ Be sure to ground the Earth Terminal (this, however, is not required in the case where a power cord with earth is used).

This product is equipped with the Earth Terminal. When installing the product, Connect the Earth Terminal to the "accurately grounded indoor earth terminal" by using an earth wire. Unless the product is grounded appropriately, the user can be subject to electric shock. After performing repair, etc. for the Control equipment, ensure that the Earth Wire is firmly connected to the Control equipment.

○ Ensure that the Power Supply used is equipped with an Earth Leakage Breaker.

This product does not incorporate the Earth Leakage Breaker. Using a power supply which is not equipped with the Earth Leakage Breaker can cause a fire when earth leakage occurs.

○ Be sure to use fuses which meet the specified rating. (only for the machines which use fuses).

Using fuses exceeding the specified rating can cause a fire and electric shock.

- **Specification changes (removal of equipment, conversion and addition) not designated by SEGA are not allowed.**

The parts of the product include warning labels for safety, covers for personal protection, etc. It is very hazardous to operate the product by removing parts and or modifying the circuits. Should doors, lids and protective parts be damaged or lost, refrain from operating the product, and contact where the product was purchased from or the office herein stated. SEGA shall not be held responsible for any accidents, compensation for damage to a third party, resulting from the specifications not designated by SEGA.

- **Ensure that the product meets the requirements of appropriate Electrical Specifications.**

Before installing the product, check for Electrical Specifications. SEGA products have a nameplate on which Electrical Specifications are described. Ensure that the product is compatible with the power supply voltage and frequency requirements of the location. Using any Electrical Specifications different from the designated Specifications can cause a fire and electric shock.

- **Install and operate the product in places where appropriate lighting is available, allowing warning labels to be clearly read.**

To ensure safety for the customers, labels and printed instructions describing potentially hazardous situation are applied to places where accidents can be caused. Ensure that where the product is operated has sufficient lighting allowing the warnings to be read. If any label is peeled off, apply it again immediately. Please place an order with where the product was purchased from or the office herein stated.

- **When handling the Monitor, be very careful. (Applies only to the product w/monitor.)**

Some of the monitor (TV) parts are subject to high tension voltage. Even after running off power, some portions are still subject to high tension voltage sometimes. Monitor repair and replacement should be performed only by those technical personnel who have knowledge of electricity and technical expertise.

- **Be sure to adjust the monitor (projector) properly. (Applies only to the product w/monitor.)**

Do not operate the product leaving on-screen flickering or blurring as it is. Using the product with the monitor not properly adjusted may cause dizziness or a headache to an operator, a player, or the customers.

- **When transporting or reselling this product, be sure to attach this manual to the product.**

In the case where commercially available monitors and printers are used in this product, only the contents relating to this product are explained herein. Some commercially available equipment has functions and reactions not stated in this manual. Read this manual together with the specific Instruction Manual of such equipment.

- Descriptions herein contained may be subject to improvement changes without notice.
- The contents described herein are fully prepared with due care. However, should any question arise or errors be found, please contact SEGA.

INSPECTIONS IMMEDIATELY AFTER TRANSPORTING THE PRODUCT TO THE LOCATION.

Normally, at the time of shipment, SEGA products are in a status allowing for usage immediately after transporting to the location. Nevertheless, an irregular situation may occur during transportation. Before turning on power, check the following points to ensure that the product has been transported in a satisfactory status.

- Are there any dented portions or defects (cuts, etc.) on the external surfaces of the cabinet?
- Are Casters and Adjusters, damaged?
- Do the power supply voltage and frequency requirements meet with those of the location?
- Are all wiring connectors correctly and securely connected? Unless connected in the correct direction, connector connections can not be made accurately. Do not insert connectors forcibly.
- Do power cords have cuts and dents?
- Do the fuses used meet specified rating? Is the Circuit Protector in an energized status?
- Are all accessories available?
- Can all Doors and Lids be opened with the Accessory keys? Can Doors and Lids be firmly closed?



TABLE OF CONTENTS

BEFORE USING THE PRODUCT, BE SURE TO READ THE FOLLOWING:

TABLE OF CONTENTS

INTRODUCTION OF THE OWNER'S MANUAL

1. HANDLING PRECAUTIONS	1 - 3
2. PRECAUTIONS CONCERNING INSTALLATION LOCATION	4 - 5
2-1 LIMITATIONS OF USAGE	4
2-2 OPERATION AREA	5
3. OPERATION	6 - 7
3-1 BEFORE OPERATION	6
3-2 DURING OPERATION (PAYING ATTENTION TO CUSTOMERS)	7
4. PART DESCRIPTIONS	8
5. ACCESSORIES	9 - 11
6. ASSEMBLING AND INSTALLATION	12 - 17
7. MANAGEMENT CHIP AND MUSHIKING CARDS	18 - 25
7-1 INSTALLING MACAGEMENT CHIP	18 - 19
7-2 MANAGEMENT CHIP ERROR CODES	19 - 20
7-3 REFILLING CARDS	21 - 22
7-4 DEALING WITH JAMMED C ARDS	23 - 25
8. PRECAUTIONS TO BE HEDED WHEN MOVING THE MACHINE	26
9. GAME DESCRIPTION	27 - 31
10. EXPLANATION OF TEST AND DATA DISPLAY	32 - 41
10 - 1 MAINTENANCE SWITCH UNIT AND COIN METER	33 - 34
10 - 2 SYSTEM TEST MODE	34
10 - 3 GAME TEST MODE	35 - 41
11. CARD DISPENSER	42
12. CARD READER (CONTROL PANEL)	43 - 45
12-1 HOW TO CLEAN THE CARD READER	43
12-2 HOW TO REMOVE THE CARD READER	44 - 45
13. POWER AND I/O BOARD UNIT	46 - 47
13-1 HOW TO REMOVE THE POWER AND I/O BOARD UNIT	46 - 47
13-2 COMPOSITION OF THE POWER AND I/O BOARD UNIT	47
14. COIN SELECTOR	48 - 49
15. MONITOR	50 - 54
15-1 CAUTIONS/WARNING REGARDING SAFETY FOR HANDLEING THE MONITOR	50 - 51
15-2 CLEANING THE CRT SURFACES AND THE MONITOR COVER	52
15-3 MONITOR ADJUSTMENT	53 - 54
16. PERIODIC INSPECTION	55
17. TROUBLESHOOTING	56 - 57
18. GAME BOARD	58 - 60
18-1 REMOVING THE GAME BOARD	58 - 59
18.2 COMPOSITION OF THE GAME BOARD	60
19. DESIGN-RELATED PARTS	61
20. PARTS LIST	62 - 90
21. WIRE COLOR CODE TABLE	91
22. WIREING DIAGRAM	XXX



SPECIFICATIONS

Installation Space	: 20 inches width X 29 inches deep
Height	: 50.5 inches
Width	: 18 inches
Length	: 25 inches
Weight	: 165.3 lbs
Power, maximum current	: 111 W 1.3 A (AC 120V 60 Hz AREA)
Card capacity	: 600 (Max.)

MONITOR	: 14" Type Sanwa Color Monitor
	Monitor part number: 998-0226
	Chassis part number: 998-0227

INTRODUCTION OF THE OWNERS MANUAL

This Owner's Manual is intended to provide detailed descriptions together with all the necessary information covering the general operation of electronic assemblies, electromechanicals, servicing control, spare parts, etc. as regards the product,

MUSHI KING U.K. TYPE.

This manual is intended for the owners, personnel and managers in charge of operation of the product. Operate the product after carefully reading and sufficiently understanding the instructions. If the product fails to function satisfactorily, non-technical personnel should under no circumstances touch the internal system. Please contact where the product was purchased from.

Use of this product is unlikely to cause physical injuries or damages to property. However, where special attention is required this is indicated by a thick line, the word "IMPORTANT" and its sign in this manual.



Indicates that mishandling the product by disregarding this display can cause the product's intrinsic performance not to be obtained, resulting in malfunctioning.

IMPORTANT!

SEGA AMUSEMENTS USA, INC. / CUSTOMER SERVICE
45133 Industrial Drive, Fremont, California 94538, U.S.A.
Phone : (415) 701-6580
Fax : (415) 701-6594

◆ PRODUCTION DATE ◆

This SEGA product was produced in the year of:

2004

This signifies that this work was disclosed in 2004.



DEFINITION OF LOCATION MAINTENANCE MAN AND SERVICEMAN



Non-technical personnel who do not have technical knowledge and expertise should refrain from performing such work that this manual requires the location's maintenance man or a serviceman to carry out, or work which is not explained in this manual. Failing to comply with this instruction can cause a severe accident such as electric shock.

Ensure that parts replacement, servicing & inspections, and troubleshooting are performed by the location's maintenance man or the serviceman. It is instructed herein that particularly hazardous work should be performed by the serviceman who has technical expertise and knowledge.

The location's maintenance man and serviceman are herein defined as follows:

"Location's Maintenance Man" :

Those who have experience in the maintenance of amusement equipment and vending machines, etc., and also participate in the servicing and control of the equipment through such routine work as equipment assembly and installation, servicing and inspections, replacement of units and consumables, etc. within the Amusement Facilities and or locations under the management of the Owner and Owner's Operators of the product.

Activities of Location's Maintenance Man :

Assembly & installation, servicing & inspections, and replacement of units & consumables as regards amusement equipment, vending machines, etc.

Serviceman :

Those who participate in the designing, manufacturing, inspections and maintenance service of the equipment at an amusement equipment manufacturer.

Those who have technical expertise equivalent to that of technical high school graduates as regards electricity, electronics and or mechanical engineering, and daily take part in the servicing & control and repair of amusement equipment.

Serviceman's Activities :

Assembly & installation and repair & adjustments of electrical, electronic and mechanical parts of amusement equipment and vending machines.

LISTED



AMUSEMENT MACHINE

Notes:



1. HANDLING PRECAUTIONS

When installing or inspecting the machine, be very careful of the following points and pay attention to ensure that the player can enjoy the game safely.

Non-compliance with the following points or inappropriate handling running counter to the cautionary matters herein stated can cause personal injury or damage to the machine.



WARNING

- Before performing work, be sure to turn power off. Performing the work without turning the power off can cause electric shocks or short circuits. In the case that work should be performed with the power ON, this will be clearly stated in the manual.
- To avoid electric shocks and short circuits, do not plug in or unplug the machine too quickly.
- To avoid electric shocks, do not plug in or unplug the machine with wet hands.
- Do not leave power cords and earth wires exposed on the surface (floor, passage, etc.). If exposed, the power cords and earth wires are susceptible to damage. Damaged cords and wires can cause electric shocks or short circuits.
- To avoid causing a fire or electric shock, do not put things on or damage power cords.
- During or after installation of the product, do not unnecessarily pull the power cord. If damaged, the power cord can cause a fire or electric shock.
- In case the power cord is damaged, ask for replacement from the point-of-purchase or the office herein stated. Using a damaged cord can cause fire, electric shock or leakage.
- Be sure to perform grounding appropriately. Inappropriate grounding can cause electric shocks.
- Be sure to use fuses meeting the specified rating. Using fuses exceeding the specified rating can cause a fire or electric shock.
- Ensure that connectors for IC BD and others are properly inserted. Insufficient insertion can cause an electric shock.
- Specification changes, removal of equipment, conversion and/or additions not designated by SEGA are not permitted.
 - Failure to observe this may cause a fire or an electric shock. Non-compliance with this instruction can have a bad influence upon the physical condition of the players or the onlookers, or result in injury during play.
 - SEGA shall not be held responsible for damage, or compensation for damage to a third party, caused by specification changes not designated by SEGA.
- Be sure to perform the periodic maintenance inspections herein stated.



ハードキャンディ
WWW.HARD-CANDY.COM

STOP IMPORTANT

- For the IC board circuit inspections, only the logic tester is allowed. The use of a multiple-purpose tester is not permitted, so be careful in this regard.
- When cleaning the CRT surfaces, use a soft and dry cloth. Do not apply chemicals such as thinner, benzine, etc.
- Static electricity from your body may damage some electronics devices on the IC board. Before handling the IC board, touch a grounded metallic surface so that the static electricity can be discharged.
- Do not turn the power on and off continuously. Repeatedly turning the power on and off may cause product malfunction or parts damage.
- Some parts are not specifically designed and manufactured for this game machine. The manufacturers may discontinue, or change the specifications of, such general-purpose parts. If this is the case, SEGA cannot repair or replace the damaged game machine, whether or not the warranty period has expired.

CONCERNING THE STICKER DISPLAY

This SEGA product has stickers attached describing the product manufacture No. (Serial No.) and Electrical Specifications. It also has a Sticker describing where to contact for repair and for purchasing parts. When inquiring about or asking for repairs, mention the Serial No. and Name of Machine indicated on the Sticker. The Serial Number indicates the product register. Identical machines could have different parts depending on the date of production. Also, improvements and modifications might have been made after the publication of this manual. In order to ensure you order the correct parts, mention the Serial No. when contacting the applicable places.

CONCERNING WARNING DISPLAYS

This SEGA product has warning displays on stickers, labels and/or printed instructions adhered/attached to or incorporated in the places where a potentially hazardous situation could arise. The warning displays are intended for accident prevention for customers and for avoiding hazardous situations relating to maintenance and servicing work. Some portions of the cabinet contain high voltage and may cause accidents if touched. When performing maintenance, be very careful of the warning displays. It is especially important that any complex repair and replacement work not mentioned herein should be performed by those technical personnel who have knowledge of electricity and technical expertise. In order to prevent accidents, caution any customer ignoring the warnings to cease and desist immediately.

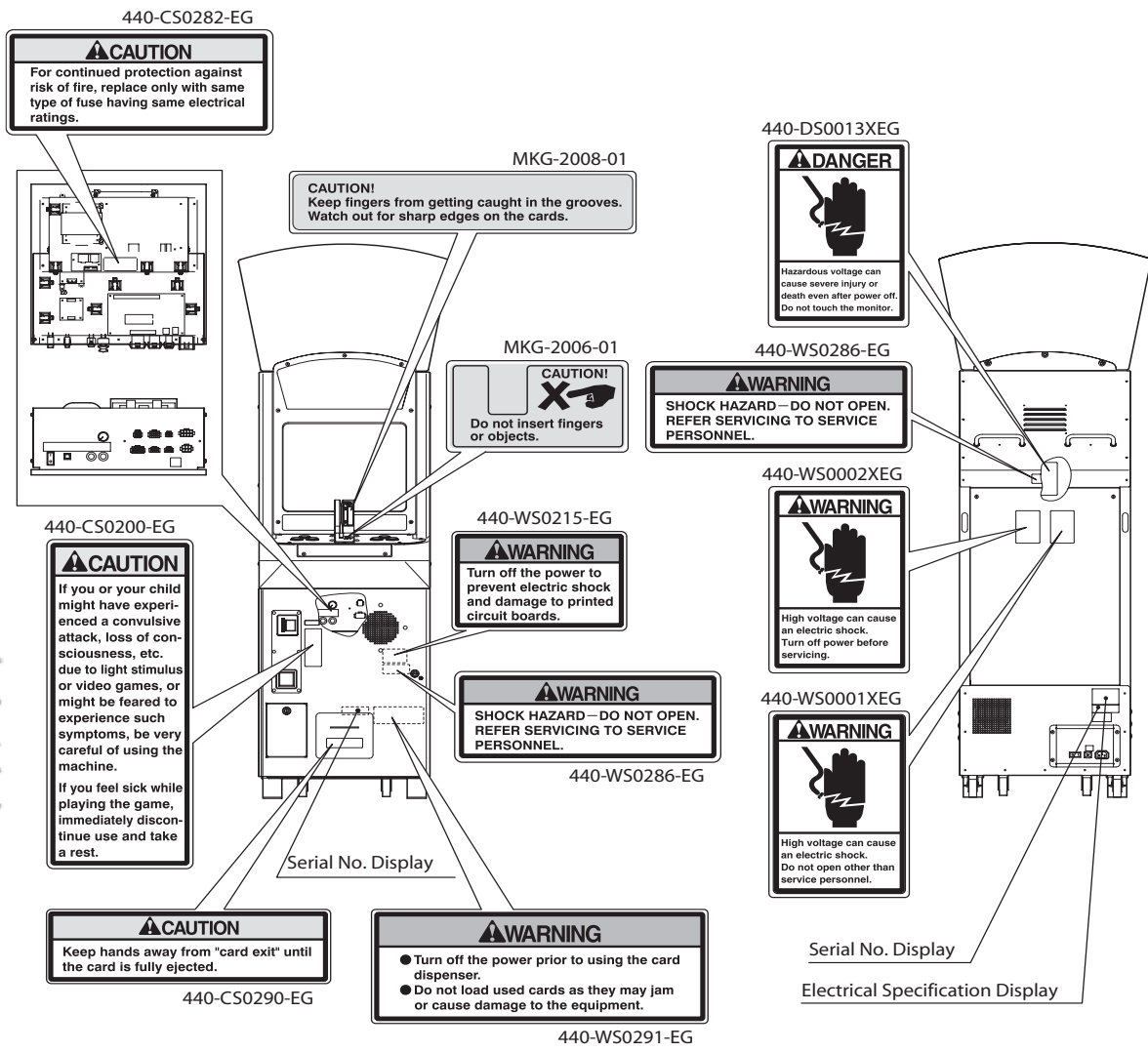

2. PRECAUTIONS REGARDING INSTALLATION LOCATION



WARNING

This product is an indoor game machine. Do not install it outside. Even indoors, avoid installing in places mentioned below so as not to cause a fire, electric shock, injury and/or malfunction.

- Places subject to rain or water leakage, or places subject to high humidity in the proximity of an indoor swimming pool and or shower, etc.
- Places subject to direct sunlight, or places subject to high temperatures in the proximity of heating units, etc.
- Places filled with inflammable gas or vicinity of highly inflammable/volatile chemicals or hazardous matter.
- Dusty places.
- Sloped surfaces.
- Places subject to any type of violent impact.
- Vicinity of anti-disaster facilities such as fire exits and fire extinguishers.
- The operating (ambient) temperature range is from 5 °C to 30 °C.

2-1 LIMITATIONS OF USAGE



WARNING

- Be sure to check the Electrical Specifications. Ensure that this product is compatible with the location's power supply, voltage and frequency requirements. A plate describing Electrical Specifications is attached to the product. Non-compliance with the Electrical Specifications can cause a fire and electric shock.
- This product requires a breaker and earth mechanism as part of the location facilities. Using the product without these can cause a fire and electric shock.
- Ensure that the indoor wiring for the power supply is rated at 7A or higher (AC single phase 100V ~ 120V area), and 4A or higher (AC 220V ~ 240V area). Non-compliance with the Electrical Specifications can cause a fire and electric shock.
- Be sure to use an independent power supply equipped with a surge-suppressor. Using a power supply without a surge-suppressor can cause an outbreak of fire if a power surge occurs.
- Putting many loads on one electrical outlet can cause generation of heat and a fire resulting from overload.
- When using an extension cord, ensure that the cord is rated at 7A or higher (AC 100V ~ 120V area) and 4A or higher (AC 220V ~ 240V area). Using a cord rated lower than the specified rating can cause a fire and electric shock.

2-2 OPERATION AREA



WARNING

- For the operation of this machine, secure a minimum area of 0.75 m (W) x 1.2 m (D). In order to prevent injury resulting from falls/accidents during game play, be sure to secure the minimum area for operation.

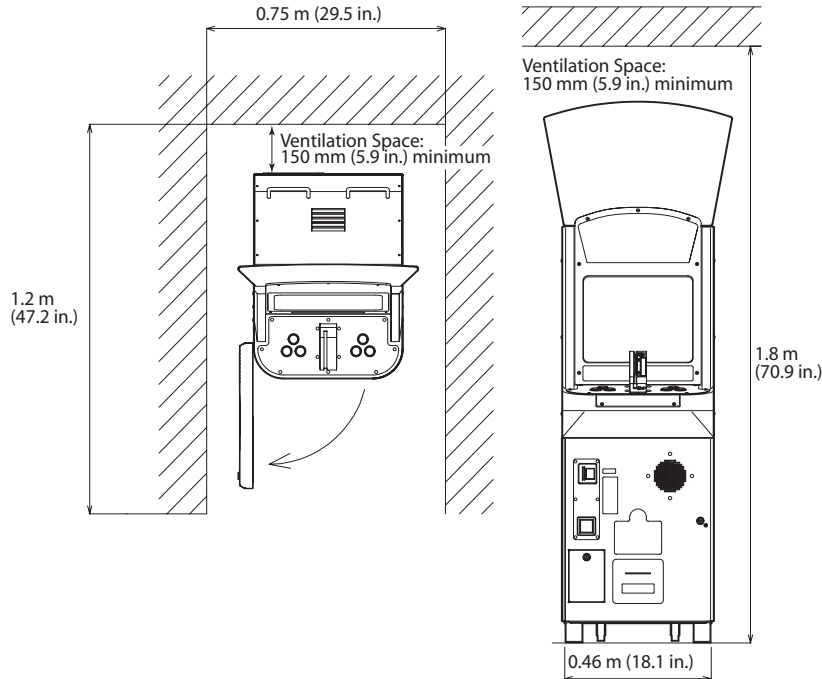

- Be sure to provide sufficient space (150 mm minimum) so as to allow this product's ventilation fan to function efficiently. To avoid machine malfunctions or fires, do not place any obstacles near the ventilation opening.
- Do not allow objects to block the ventilation ports. It can cause generation of heat and a fire.
- SEGA shall not be held responsible for damage or compensation for damage to a third party, resulting from the failure to observe this instruction.

2

PRECAUTIONS REGARDING INSTALLATION LOCATION

STOP

IMPORTANT

In order to transport the machine into a building, the minimum necessary dimensions of the opening (of doors, etc.) are 0.5 m (19.7 in.) [W] and 1.3 m (51.2 in.) [H].

Electricity Consumption:

MAX. 1.3 A	(AC 120 V, 60 Hz)
MAX. 0.7 A	(AC 220 V, 50 Hz)
MAX. 0.7 A	(AC 220 V, 60 Hz)
MAX. 0.7 A	(AC 240 V, 50 Hz)
MAX. 1.5 A	(AC 110 V, 60 Hz) <TAIWAN>

HARD CANDY
 WWW.FRODO-CANDY.COM
 ハード

3. PRECAUTIONS REGARDING PRODUCT OPERATION

3-1 BEFORE OPERATION

To avoid injury and trouble, be sure to pay attention to the behavior of visitors and players.



WARNING

In order to avoid accidents, check the following before starting the operation:

- To ensure maximum safety for the players and the customers, ensure that where the product is operated has sufficient lighting to allow any warnings to be read. Operation under insufficient lighting can cause players to bump into each other, causing trouble between customers.
- Be sure to perform appropriate adjustment of the monitor (projector). Do not leave the machine operating with monitor flickering or malfunctioning. Failure to observe this can have a bad influence upon the players' or the customers' physical condition.
- It is suggested to ensure a space for players who feel sick while playing the game to take a rest.
- Check if all of the adjusters are in contact with the surface. If they are not, the cabinet can move and cause an accident.
- Do not put any heavy items on this product. Placing heavy items on the product can cause accidents or parts damage.
- Do not climb on the product. Climbing on the product can cause accidents. To check the top portion of the product, use a step.
- To avoid electric shock, check that no door & cover parts are damaged or missing.
- To avoid electric shock, short circuit and or parts damage, do not put the following items on or in the periphery of the product. Flower vases, flowerpots, cups, water tanks, cosmetics, and receptacles/containers/vessels containing chemicals or water.

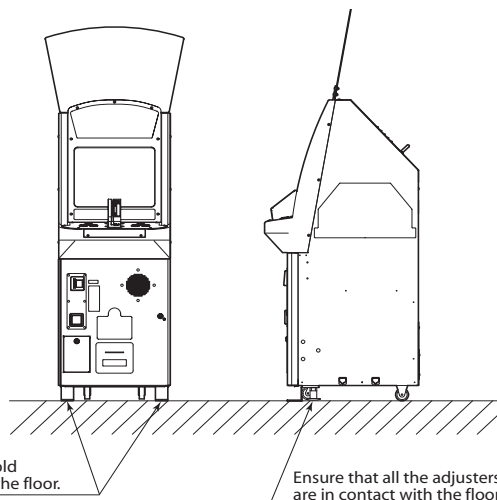

CAUTION

To avoid injury, be sure to provide sufficient space by considering the crowd situation at the installation location. Insufficient installation space can cause customers to bump into each other, causing trouble.

HARD CANDY
WWW.HARD-CANDY.COM

3-2 DURING OPERATION (PAYING ATTENTION TO CUSTOMERS)

To avoid injury and trouble, be sure to pay attention to the behavior of visitors and players.



WARNING

- To avoid injury and accidents, those who fall under the following categories are not allowed to play the game.
 - Those who need assistance such as the use of an apparatus when walking.
 - Those who have high blood pressure or a heart problem.
 - Those who have experienced muscle convulsion or loss of consciousness when playing video games, etc.
 - Those who have neck or spinal cord problems.
- * Intoxicated persons.
- * Pregnant women or those who could be pregnant.
- * Persons susceptible to motion sickness.
- * Persons who disregard the product's warning displays.
- Even players who have never been adversely affected by light stimulus might experience dizziness or headache depending on their physical condition when playing the game. Small children are especially likely to experience these symptoms. Caution guardians of small children to keep watch on their children during play.
- It is suggested to provide a space for players who feel sick while playing the game to take a rest.
- Instruct those who feel sick during play to have a medical examination.
- To avoid injury from falls and electric shocks due to spilled drinks, instruct the player not to place heavy items or drinks on the product.
- To avoid electric shocks and short circuits, do not allow customers to put hands and fingers or extraneous matter in the openings of the product or small openings in or around the doors.
- To avoid falls and resulting injury, immediately stop the customer from leaning against or climbing on the product, etc.
- To avoid electric shocks and short circuits, do not allow customers to unplug the power plug without a justifiable reason.



CAUTION

Immediately stop such violent acts as hitting and kicking the product. Such violent acts can cause parts damage or cause the cabinet to fall over, resulting in injury.

STOP

IMPORTANT

Please take care not to offend or disturb customers when moving/removing the machine from its current location.

HARD CANDY

4. PART DESCRIPTIONS

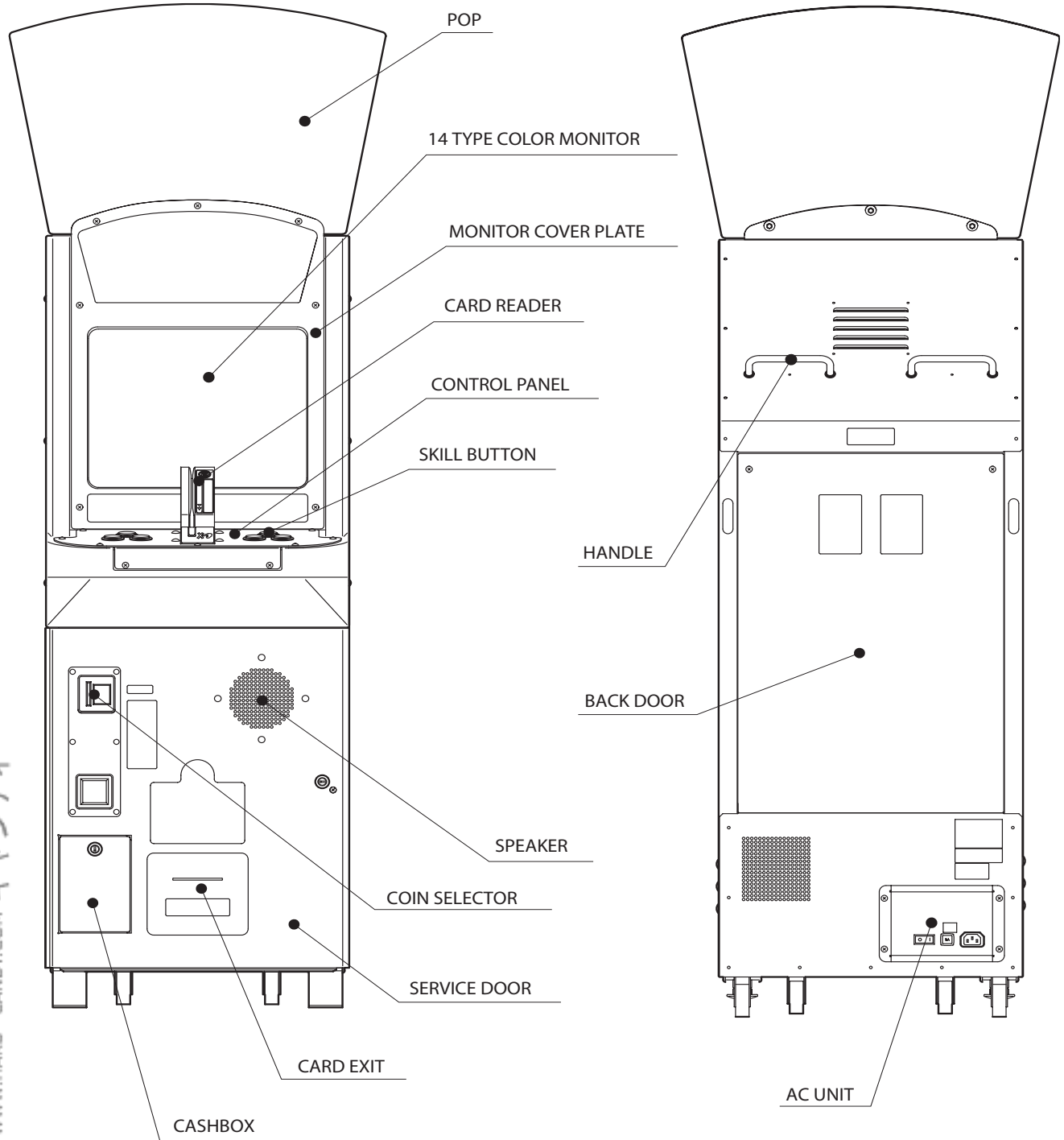



FIG. 4

HARD CANDY
 ハードキャンディ
 WWW.HARD--CANDY.COM

5. ACCESSORIES

Confirm that the accessories listed in the table below are present when setting up the product.
 Accessories marked "Spare" in the "Intended Use" column are consumable items but included as spares.

TABLE 5a ACCESSORIES

<p>DESCRIPTION</p> <p>Part No. (Qty.)</p> <p>Note</p> <p>Figures</p> <p>Parts not labeled with part numbers are as yet unregistered or cannot be registered. Be sure to handle all parts with care, as some parts are not available for purchase separately.</p>	<p>OWNER'S MANUAL</p> <p>999-2187 (1)</p> <p>This manual</p>	<p>KEY MASTER</p> <p>220-5785 (2)</p> <p>For opening/closing the door</p>	<p>KEY (2)</p> <p>For the cashbox door</p> <p>The keys are inside the service door (near the cashbox side) at the time of shipment from the factory.</p>
			

5
ACCESSORIES

The following Table 5b lists the parts that had been separately packed when the product was shipped from the factory but are necessary when you use the product. These parts will be mounted on the product when installing and assembling it.

- Magnetic Cards
 601-11358-01 CARD PACKAGE MKG ENG: Package of 200 Magnetic Cards

TABLE 5b ACCESSORIES

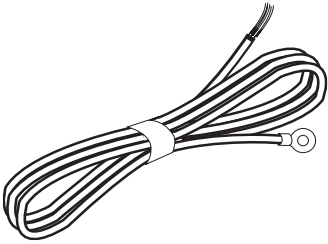
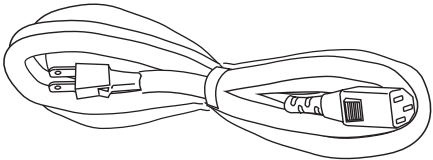
	<p>WIRE HARN EARTH W/LUG M6</p> <p>660-6664-02 (1) <TAIWAN></p> <p>Used for installation, see Section 6, [2].</p>
	
<p>AC CABLE (POWER CORD)</p> <p>600-7228 or 600-6729 (1) <TAIWAN></p> <p>600-6619-01 (1) <HONG KONG></p> <p>600-6618 (1) <AC 220V ~ 240V AREA></p> <p>Used for installation, see Section 6, [2].</p>	

HARD CANDY
 ハート WWW.HARD-CANDY.COM キャンティ

TAMPERPROOF WRENCH
M4 540-0006-01 (1)

Tool

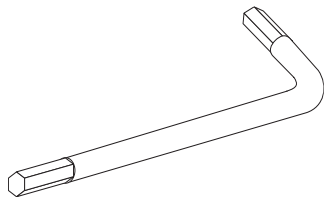

NAOMI SERVICE MANUAL
420-6455-01 (1)

Instruction Manual for the Game Board

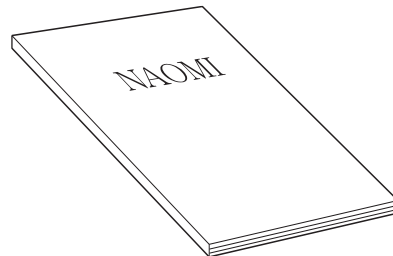

CLEANING CARD
MKG-0011-01 (1)

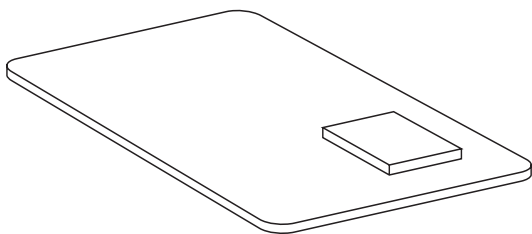

TRUSS SCREW (CHROME)
000-T00414-0C (3)

Used for securing POP, see Section 6, [3].

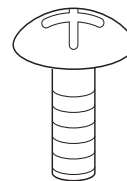

CARTON BOX
601-10532 (1)

Used for transporting NAOMI Board Case (see next page).

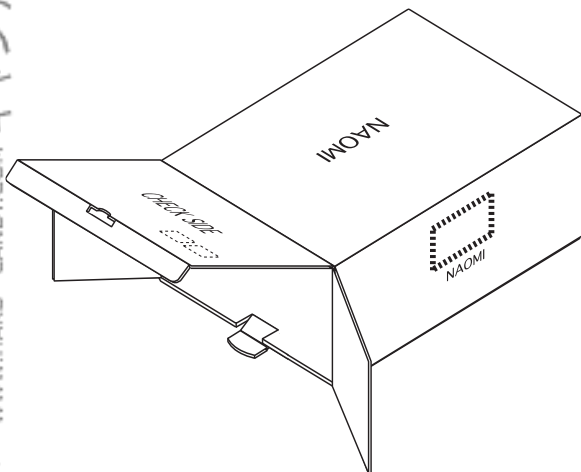

POP MUSHI ENG
MKG-0009-01 (1)

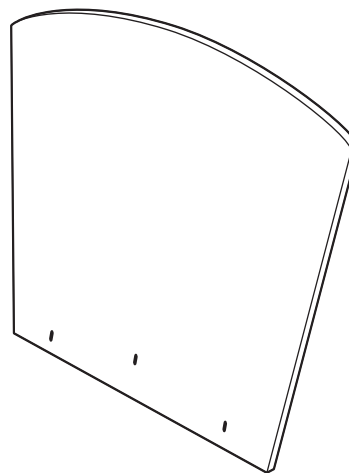

HOW TO USE THE CARTON BOX

STOP IMPORTANT

When requesting for the replacement/repair of this product's Game Board (NAOMI BOARD), follow the instructions below. Transporting the Game Board in an undesignated status is unacceptable. Improper handling can cause damage to the parts.

- Put the Game Board in the Carton Box together with the Shield Case. Do not unnecessarily disassemble nor remove parts.
- By paying careful attention to the following Figure and the directions shown on the Carton Box printing, put the Shield Case in the Carton Box.
- When putting the Shield Case in the Carton Box, do not remove Leg Brackets.
- The projected portion of the packing material is intended for cushioning. Therefore, do not bend the projected portion.

5

ACCESSORIES

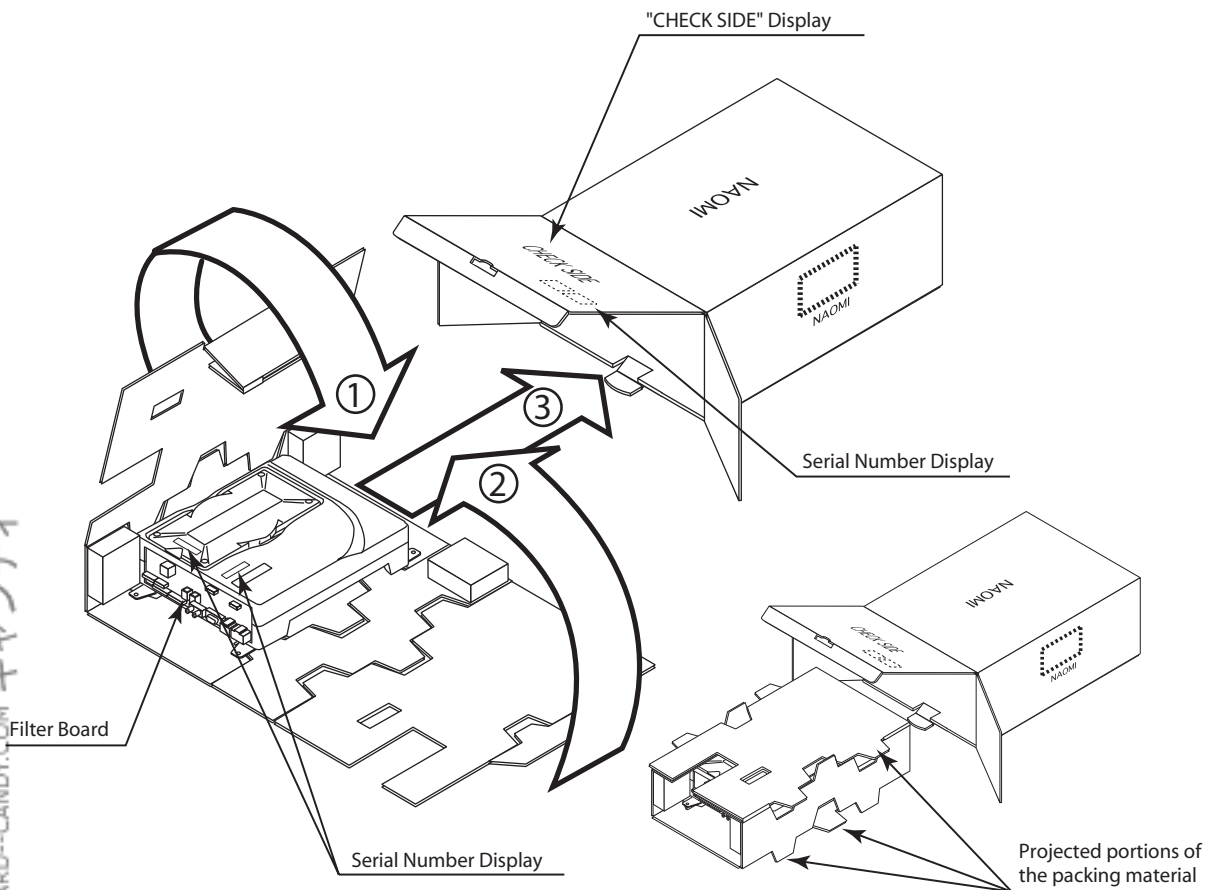

Fold the packing material in the sequential order of the numbers as shown in the figure, enfold the Shield Case and put it in the Carton Box. If it is placed upside down, or is not packed upright as illustrated, the Game Board and other parts will be damaged.

6. ASSEMBLY AND INSTALLATION



WARNING

- Perform assembly work by following the procedure herein stated. Failure to comply with the instructions can cause electric shock.
- Perform assembling as per this manual. Since this is a complex machine, incorrect assembling can cause an electric shock, machine damage and/or improper functioning as per specified performance.
- Ensure that connectors are accurately connected. Incomplete connections can cause electric shock.
- Be careful not to damage the wires. Damaged wires may cause electric shock, short circuit or present a risk of fire.
- This work should be performed by the site maintenance individual or other skilled professional. Performing work by non-technical personnel can cause a severe accident such as electric shock. Failing to comply with this instruction can cause a severe accident such as electric shock to the player during operation.
- Provide sufficient space so that assembling can be performed. Performing work in places with narrow space or low ceiling may cause an accident and assembly work to be difficult.
- To perform work safely and avoid serious accidents such as the cabinet falling down, do not perform work in places where step-like grade differences, a ditch, or slope exist.



CAUTION

Handle molded parts with care. Excessive weight or pressure may cause them to break and the broken pieces may cause injury.

When carrying out the assembling and installation, follow the following 6-item sequence.

- [1] SECURING IN PLACE (ADJUSTER ADJUSTMENT)
- [2] POWER SUPPLY AND EARTH CONNECTION
- [3] ASSEMBLING THE POP
- [4] INSERTING THE MANAGEMENT CHIP AND MUSHIKING CARDS (See Section 7)
- [5] POWERING ON
- [6] ASSEMBLY CHECK

Tools and Implements Required for the Work

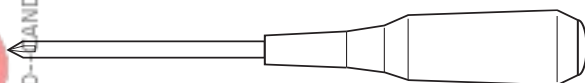

Phillips screwdriver (for M4 screws)

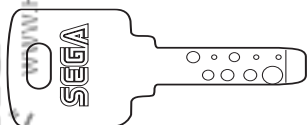

Master key

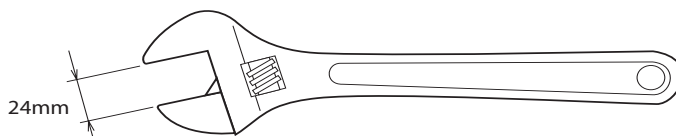

Spanner with a jaw width of 24 mm (for M16 hexagon bolts)

[1] SECURING IN PLACE (ADJUSTER ADJUSTMENT)



WARNING

- Make sure that all the adjusters are resting on the floor. The cabinet may move and cause an accident if the adjusters are not laid out properly.



IMPORTANT

The adjusters are made of metal and therefore present a risk of damaging the floor. Please keep this in mind when positioning the cabinet.

6

ASSEMBLY AND INSTALLATION

The cabinet is equipped with 4 casters and 2 adjusters.

After deciding on a location, bring the adjusters into direct contact with the ground and adjust the cabinet so that it is completely level.

1. Move the cabinet to the desired location. Make sure there is space in the back for air to flow.
2. Bring the adjusters into direct contact with the floor. Use a wrench to align the height of the adjusters until the cabinet is perfectly level. If the floor is level, the machine should be level with the casters about 5 millimeters from the floor. (FIG. 6.1c)
3. After making the final adjustments, fix the adjuster height by tightening up the adjuster nuts.

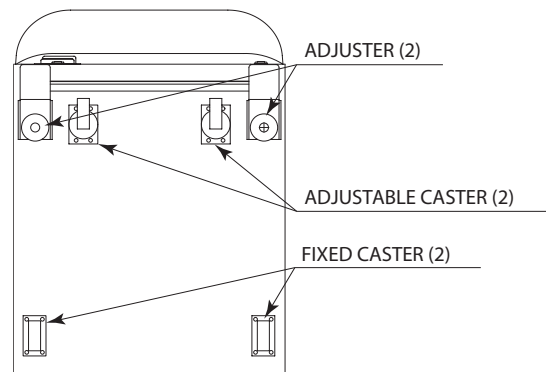

FIG. 6.1a Bottom View

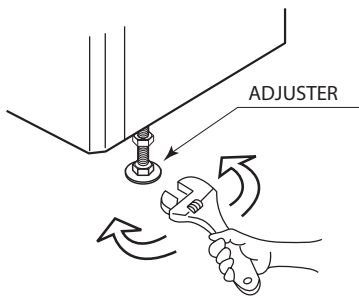

FIG. 6.1b

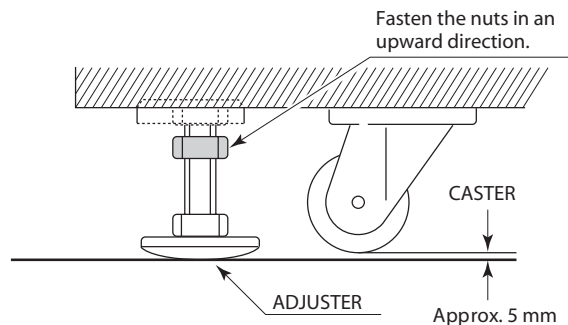

FIG. 6.1c Aligning the Adjusters

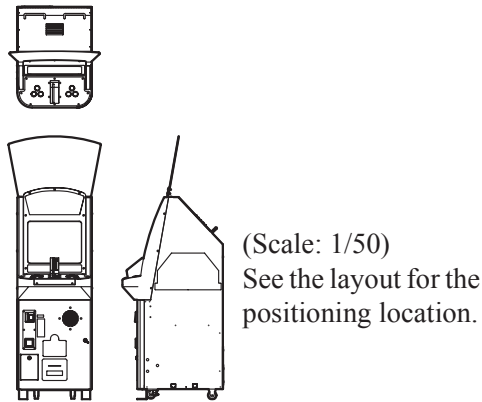

FIG. 6.1d

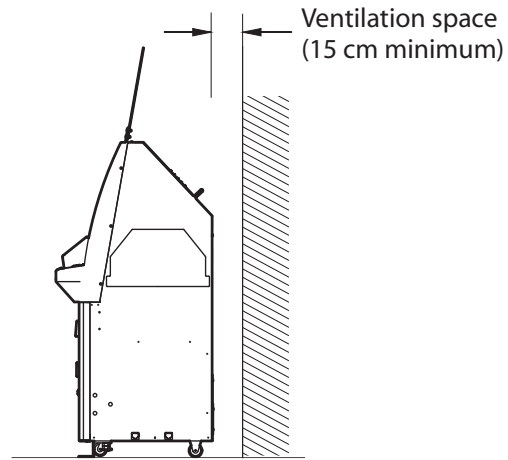

FIG. 6.1e Ensuring Ventilation Space

[2] POWER SUPPLY AND EARTH CONNECTION



WARNING

- Be sure to independently use the power supply socket outlet equipped with an Surge Suppressor. Using a power supply without a Surge Suppressor can cause a fire when electric leakage occurs.
- Ensure that the "accurately grounded indoor earth terminal" and the earth wire cable are available (except in the case where a power cord plug with earth is used). This product is equipped with an earth terminal. Connect the earth terminal and the indoor earth terminal with the designated cable. If the grounding work is not performed appropriately, customers can be subjected to an electric shock, and the product may not function properly.
- Ensure that the power cord and earth wire are not exposed on the surface (passage, etc.). If exposed, they can be caught and are susceptible to damage. If damaged, the cord and wire can cause electric shock and short circuit accidents. Ensure that the wire is not in the customer's way and that the wiring has protective insulation.
- After wiring the power cord on the floor, be sure to protect the power cord. An exposed power cord is susceptible to damage and may cause an electric shock.

The AC unit is located at the back of the cabinet.
The AC unit features a main switch, a circuit protector, and an inlet for connecting the power cord.

1. Ensure that the main switch is OFF.
2. Connect one end of the earth wire to the AC Unit earth terminal, and the other end to the indoor earth terminal. The AC Unit earth terminal has a Bolt and Nut combination. Take off the Nut, pass the earth wire through the Bolt, and fasten the nut.
<For Taiwan>

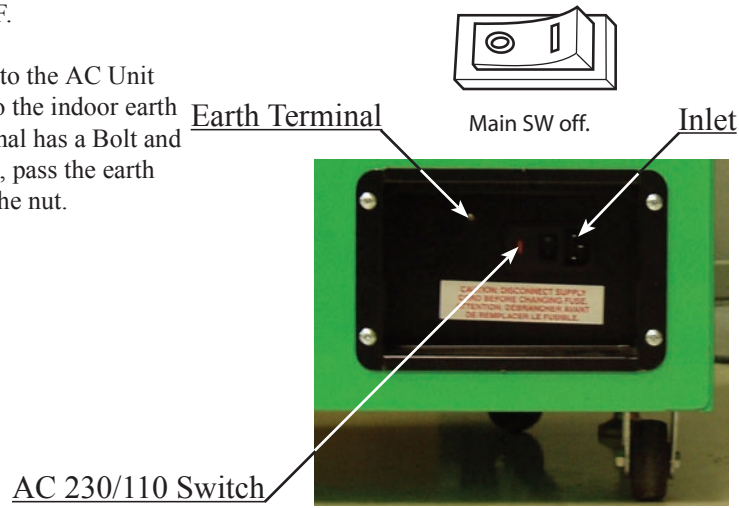

FIG. 6.2a AC Unit

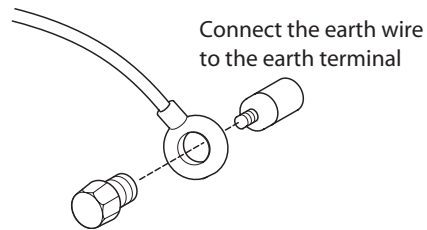

FIG. 6.2b *Earth Wire Connection

**Note that the earth wire is incorporated in the power cord for the Areas of AC 120V (USA) and AC 220 ~ 240V, and therefore, this procedure is not necessary.*

3. Firmly insert the power plug into the socket outlet. Insert the opposite side of the power cord plug to the AC Unit's connector ("INLET").

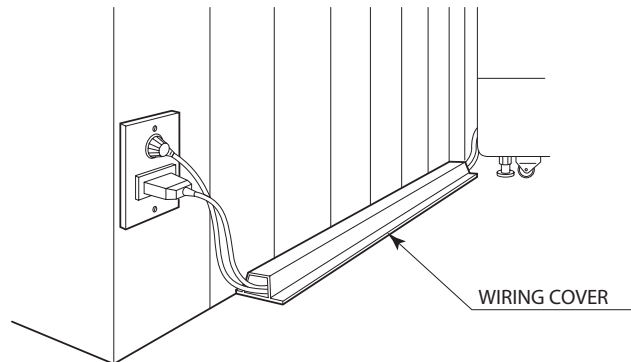
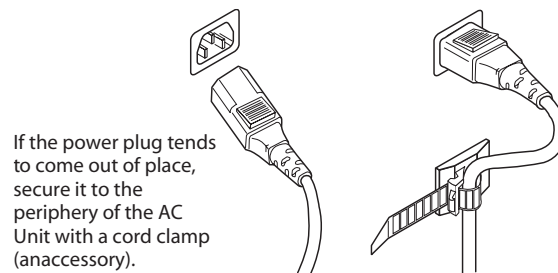

FIG. 6.2c Connecting the Power Cord and Earth Wire

4. Perform wiring for the power cord and earth wire. Install protective insulation for the power cord and earth wire.



If the power plug tends to come out of place, secure it to the periphery of the AC Unit with a cord clamp (an accessory).

FIG. 6.2d

[3] ASSEMBLING THE POP

Remove the 3 truss screws (M4 x 12) from the cabinet, replacing them with the 3 supplied truss screws (M4 x 14), and fasten the POP as shown in the figure on the right.

The POP support board for this machine is packed in air-wrap and secured to the front of the monitor cover.

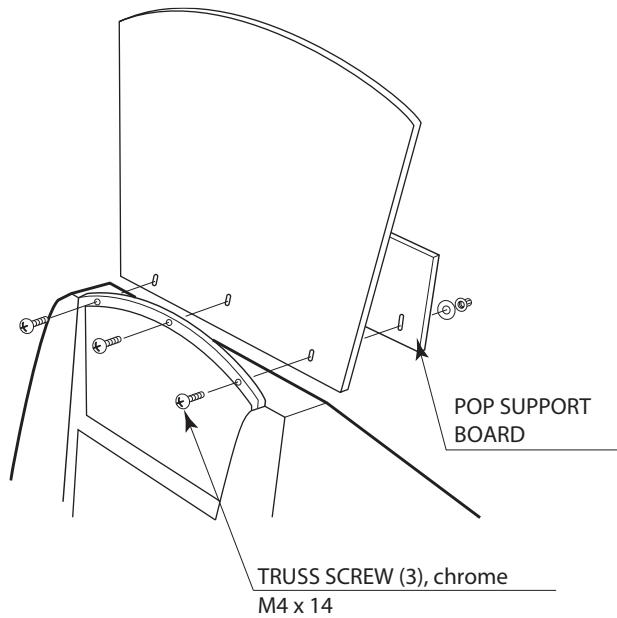

FIG. 6.3a

[4] INSERTING THE MANAGEMENT CHIP AND MUSHIKING CARDS

While consulting section 7, "MANAGEMENT CHIP AND MUSHIKING CARDS", insert the Management Chip into the Management Chip reader/writer, and load the cards into the card dispenser.

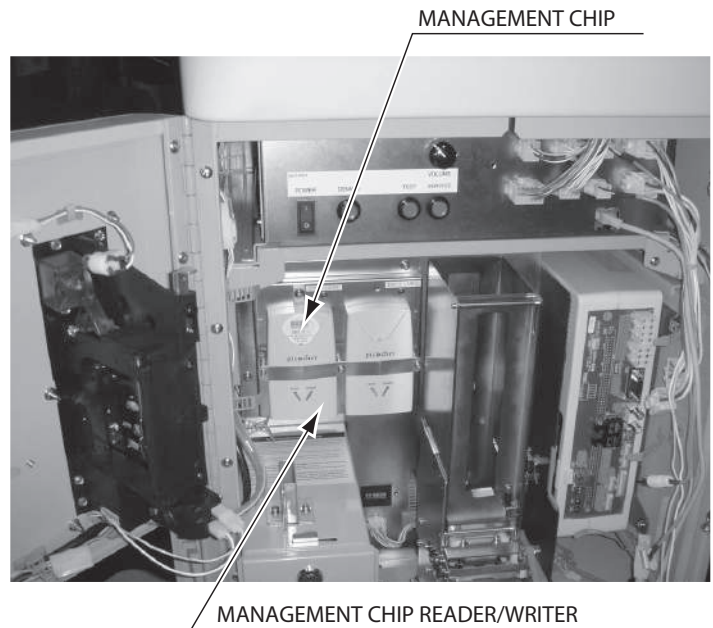

PHOTO 6.4

[5] POWERING ON

STOP IMPORTANT

This machine cannot be powered on unless both the AC unit on the back of the cabinet and the power switch in the maintenance switch section on the inside of the service door are both turned on.

Turning on the AC unit main switch and the maintenance switch will power on the machine. When powering on the machine, the system start-up screen will be displayed, and an advertisement screen will be shown afterwards. On this machine, the number of credits will be saved even after shutting off the power. If credits allowing further play remain in the machine when powered off, a card will be dispensed and a game will begin when the machine is restarted.

- In the event that there are no cards loaded into the card dispenser, a "CARD ERROR" message screen will be displayed. In such a case, turn off the machine, load cards, and turn it on again.
- In the maintenance switch section of the service door, use the audio volume adjuster to regulate the volume. Also, the choice of whether or not to play sound during the advertisement screen can be selected in the TEST MODE settings.

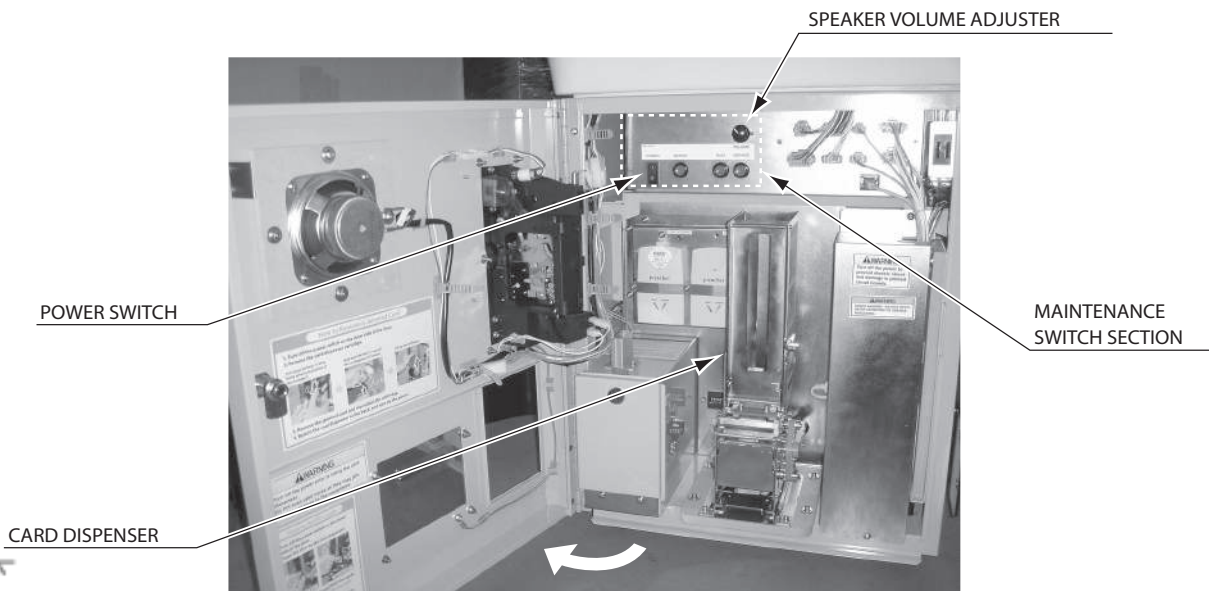

PHOTO 6.5 Inside the Service Door

[6] ASSEMBLY CHECK

After powering on, press the SERVICE Button in the maintenance switch section to make sure that the machine is working properly.

Selecting "Play against a friend" will allow a quick, general check of the working order of the machine. Use the 1P Button and 2P Button where one of the two will advance in a rock-scissors-paper game. Be sure to use all the input buttons when checking at this time.

Confirm the following items during operation:

- Are the cards dispensed properly?
- Does the game proceed properly on the screen?
- Do the input buttons work properly?
- Is the card scan carried out properly?

For more detailed, specific confirmation, refer to the TEST MODE. (See Table 10 of Section 10.)

7. MANAGEMENT CHIP AND MUSHIKING CARDS



WARNING

- Turn off the power prior to using the card dispenser.
- Do not load used cards as they may jam or cause damage to the equipment.

STOP IMPORTANT

Do not perform any of the following actions to avoid damaging the machine.

- Removing the Management Chip or turning the power on/off when the red Management Chip reader/writer "BUSY" lamp is flashing.
- Removing/inserting Management Chips while a game is in progress.
- Inserting Management Chips/Cards designed for other machines or game versions.
- Loading more than the maximum number of cards (600). Doing so can result in card jamming or faulty dispensing.

7-1 INSTALLING MANAGEMENT CHIP

The Management Chip is supplied with the card set for use with this machine.

1. Turn off the power switch inside the door.
2. Loosen the screw locking the Management Chip holder.
3. Insert the Management Chip firmly into the Management Chip reader/writer slot.
4. Turn on the power switch inside the door.
5. If the "EMPTY LAMP" lights up, there may be a malfunction. Check that the chip is correctly inserted.

Notes:

Be sure to turn the power off and on again when inserting/removing Management Chips, even if the machine is in use.

The counter in the Management Chip is set for the number of cards in one carton, and each dispensed card reduces the counter number by 1.

One Management Chip allows game operation for one carton of cards.



PHOTO 7-1

When the credits reach zero and the warning screen is displayed, install a new Management Chip.

A Management Chip that causes the "EMPTY LAMP" to light up cannot be used.

There are two reader/writer units. If the chip is recognized by either one of them, the game can be operated.

The status of the chip can be verified in Test Mode.

MANAGEMENT CHIP INDICATORS

- **POWER LAMP:** The green lamp lights up when the machine has properly recognized the reader/writer units.
- **BUSY LAMP:** The red lamp flashes when the reader/writer is communicating with the Management Chip. Do not remove the Management Chip when the lamp is blinking. In addition, do not turn the power off or perform any other operations on the machine.
- **EMPTY LAMP:** This lamp lights up when either the credits for the Management Chip reach zero or when an error has occurred with the Management Chip reader/writer.

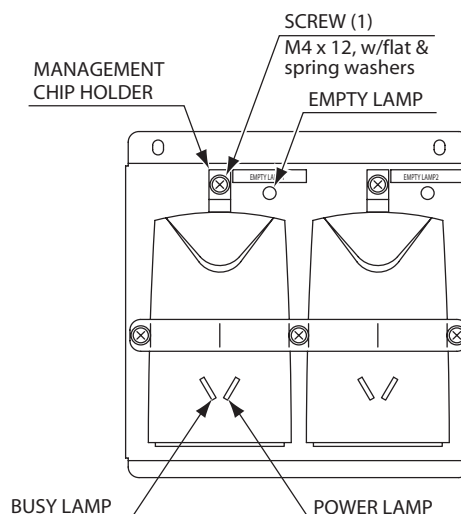

FIG. 7-1

7-2 MANAGEMENT CHIP ERROR CODES

When problems occur with the Management Chip, the following error codes will be displayed on the screen. Refer to the "cause" and "countermeasures" list below in order to deal with the problem appropriately. The following error codes will not be displayed if either the Management Chip or the reader/writer is functioning properly.

ERROR 50: Management Chip, reader/writer error

[DISPLAY]

ERROR 50
RFID READER NOT READY
(If the error occurs in Test Mode, "READER NOT READY" is displayed)

[CAUSE]

The wire connection is not properly configured, or there may be a broken wire or damaged hardware.

[COUNTERMEASURES]

Turn off the power, check the wire connection, and then restart the machine. If the problem still persists, the machine may be damaged. Replace broken parts with new ones.

ERROR 51: Management Chip read error

[DISPLAY]

ERROR 51
RFID READ ERROR
(If the error occurs in Test Mode, "READ ERROR" is displayed)

[CAUSE]

- (1) The wire connection is not configured properly, or there may be a broken wire or damaged hardware.
- (2) The Management Chip is not inserted properly in the slot.

[COUNTERMEASURES]

- (1) Turn off the power, check the wire connection, and then restart the machine. If the problem still persists, the machine may be damaged. Replace broken parts with new ones.
- (2) Check the status of the Management Chip and reinsert it. The chip may be damaged. Replace it with a new one if necessary.

ERROR 52: Management Chip write error

[DISPLAY]

ERROR 52
RFID WRITE ERROR

[CAUSE]

The process of writing data to the Management Chip does not complete properly. The verified data does not match the results of the data check. The Management Chip is not inserted properly in the slot.

[COUNTERMEASURES]

Reinsert the Management Chip properly. If the problem still persists, the chip may be damaged. Replace it with a new one.



ERROR 53: Management Chip decrement error

- [DISPLAY]** ERROR 53
RFID DECREMENT ERROR
- [CAUSE]** The process of credit reduction does not complete properly. The counter does not decrease by 1 after the reduction process. The Management Chip is not inserted properly in the slot.
- [COUNTERMEASURES]** Reinsert the Management Chip properly. If the problem still persists, the chip may be damaged. Replace it with a new one.

ERROR 54: Management Chip data error 1

- [DISPLAY]** ERROR 54
RFID UNKNOWN ERROR
(If the error occurs in Test Mode, "UNKNOWN CHIP FORMAT" is displayed)
- [CAUSE]** The inserted Management Chip is not for the correct machine or game version.
- [COUNTERMEASURES]** Verify again that the Management Chip is correct.

ERROR 55: Management Chip data error 2

- [DISPLAY]** ERROR 55
AN ILLEGAL USE ERROR
(If the error occurs in Test Mode, "THIS CHIP IS INVALID" is displayed)
- [CAUSE]** The inserted Management Chip has been used previously and is illegal because its remaining credits have increased.
- [COUNTERMEASURES]** Verify again that the Management Chip is correct.

WARNING DISPLAY FOR MANAGEMENT CHIP EXPIRATION

- [DISPLAY]** Refer to the screen display on the right.
(If the error occurs in Test Mode, "0" is displayed without an error message.)
- [CAUSE]** The remaining credits on the Management Chip counter is "0".
- [COUNTERMEASURES]** When this screen appears, quickly replace the chip with a new one, or a chip that still has remaining credits.



Note: This screen only appears when all the chips installed in the reader/writer units have no remaining credits left.

7-3 REFILLING CARDS

When the card stock runs out while the game is operating, a warning screen will be displayed. If this screen is displayed, be sure to promptly refill the cards.



PHOTO 7-3a Warning Screen when Out of Cards

HOW TO REFILL CARDS

1. Open the service door and turn off the power switch in the maintenance switch section.

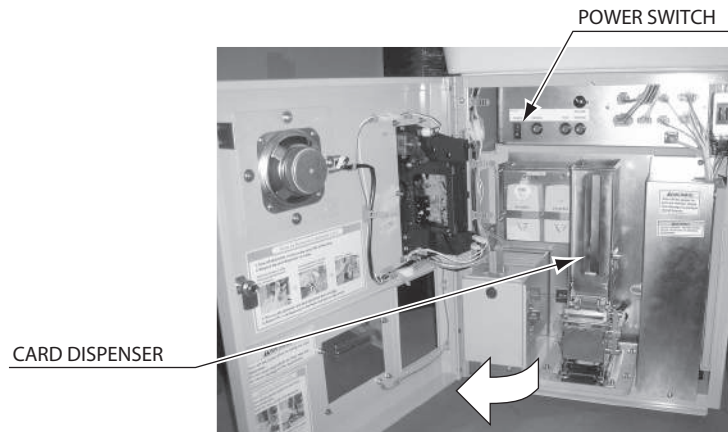

PHOTO 7-3b

2. While pushing the lever, raise it to open up the dispenser.

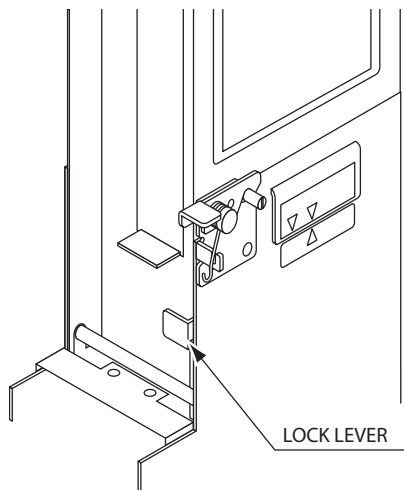

FIG. 7-3a

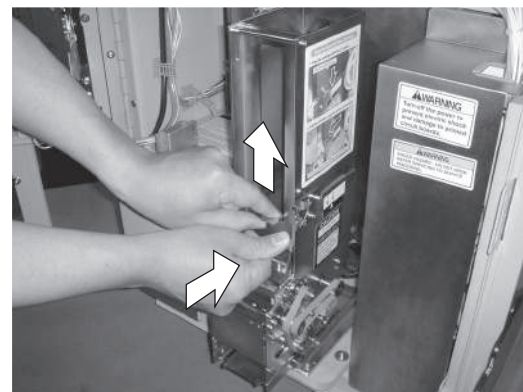

PHOTO 7-3c

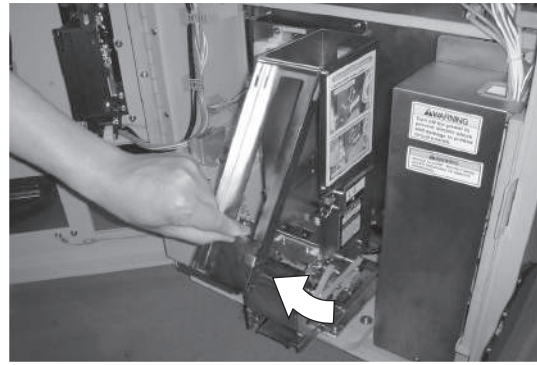

PHOTO 7-3d

3. Take out the card weight. This part is covered in an air-wrap bag at the time of shipping.

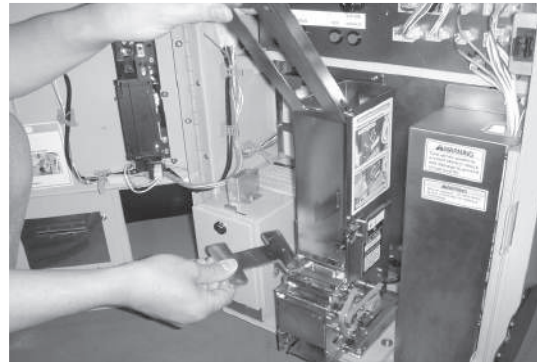

PHOTO 7-3e

4. Take the wrapping off the new cards and gently riffle through them.
 - Load the cards with the front faced down.
 - Cards come in packs of 200.



PHOTO 7-3f

5. Refill the cards. Do not load more than 600 cards.
6. Reposition the weight and close the refill door.
7. Turn the power back on and close the service door.



PHOTO 7-3g

7-4 DEALING WITH JAMMED CARDS

If a card jam occurs while the game is operating, a warning screen will be displayed. If this screen is displayed, be sure to remove the jammed card immediately.



PHOTO 7-4a Jammed Card Warning Screen

HOW TO REMOVE A JAMMED CARD

1. Open the service door and turn off the power switch in the maintenance switch section.
2. Hold down the lock lever on the bottom section of the card dispenser and pull out the card dispenser.

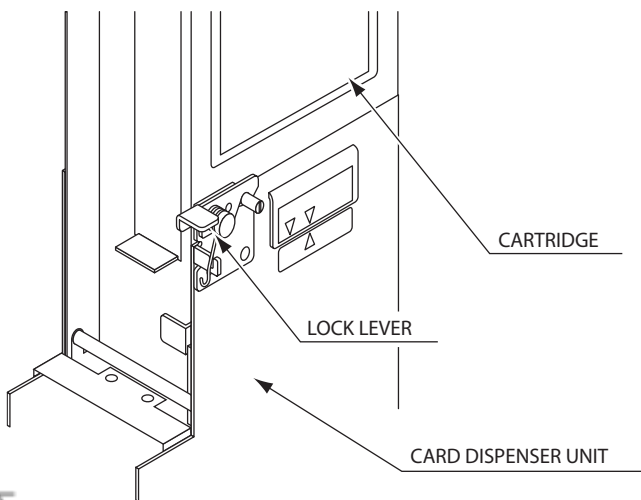

FIG. 7-4a

3. Push firmly on the front bottom of the cartridge while holding down the lock lever on the right. The cartridge will slide back and stop.

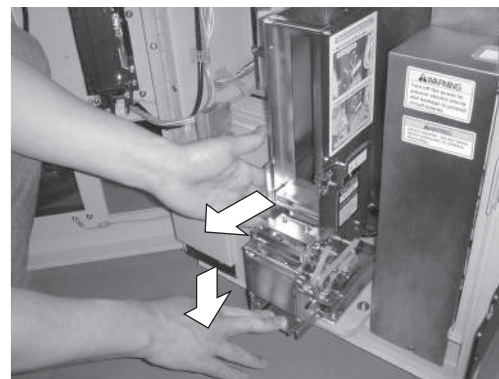

PHOTO 7-4b

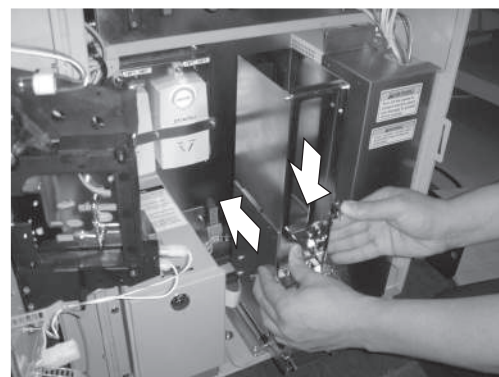

PHOTO 7-4c

- Lift up and release the cartridge. In some cases the bottom-most card will be stuck but proceed to lift up the cartridge. Afterwards, remove the jammed card.

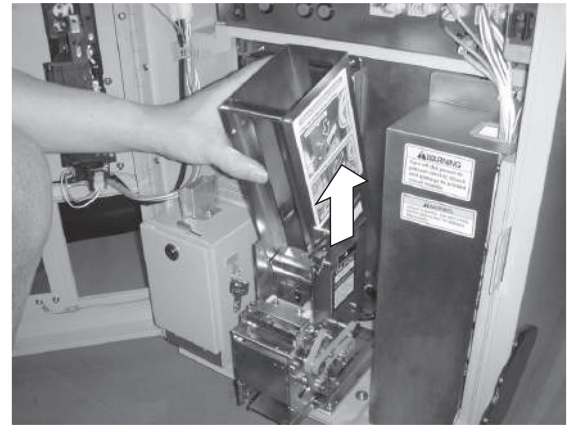

PHOTO 7-4d

- Reposition the cartridge. Align the cartridge with the Δ symbol by pushing firmly from above. Then pull the cartridge forward with both hands as shown in the picture

Reinstalling the cartridge improperly will result in card dispenser malfunctions. Be sure to consult the diagram below and proceed carefully.

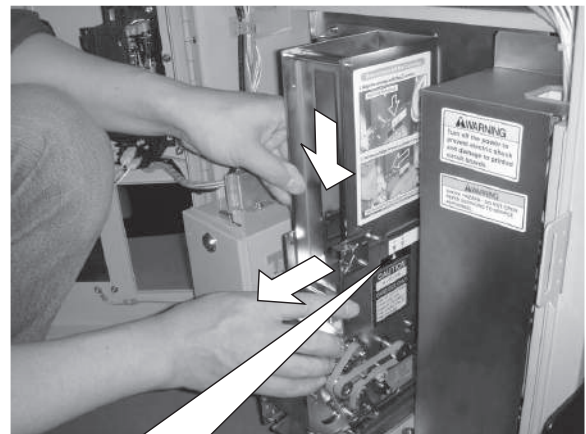
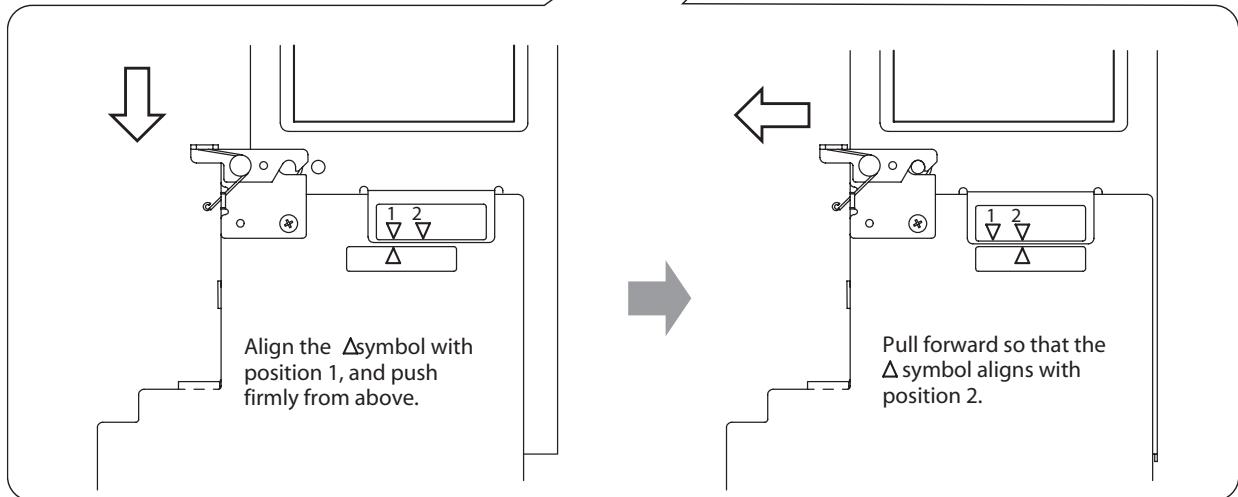

PHOTO 7-4e



6. Return the card dispenser to the back.
7. Turn the power back on and close the service door.

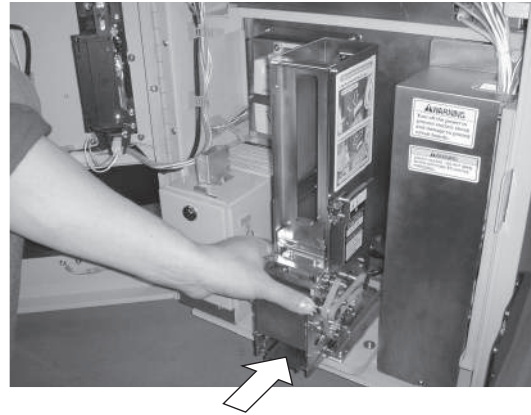
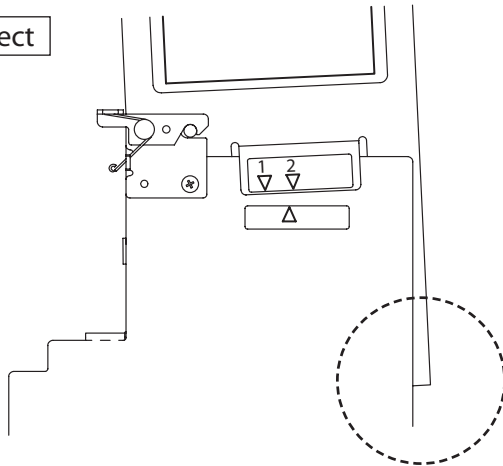

PHOTO 7-4f

CARTRIDGE REINSTALLATION WARNING

As shown in the diagram, be sure that the cartridge is not slanted off center and that the cartridge tabs are locked securely into the card dispenser.

Incorrect



Side View

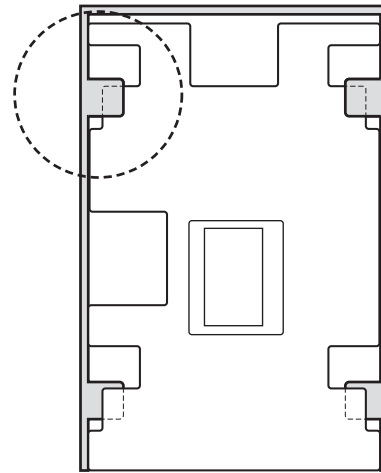

To p View

Correct

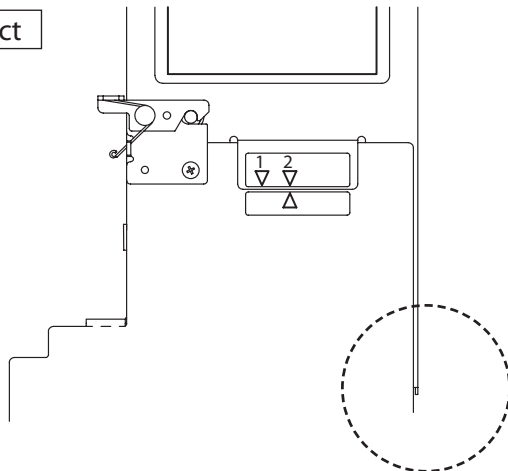

Side View

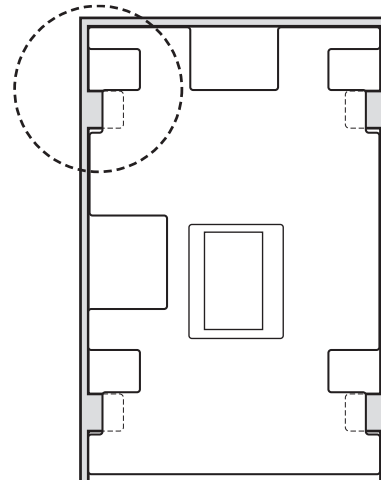

Top View

8. PRECAUTIONS WHEN MOVING THE MACHINE



WARNING

- When moving the machine, be sure to pull out the plug from the power supply. Moving the machine with the plug still inserted can cause the power cord to be damaged, resulting in a fire and/or electric shock.
- When moving the machine on the floor, remove the hold brackets and retract the adjusters, and ensure that the casters make contact with the floor. Pay careful attention so that the casters do not run over power cords and earth wires. Damaging the power cords can cause an electric shock and/or short circuit.
- When the casters are in contact with the floor, it is possible that the cabinet can move under its own weight if placed on an uneven area. Please be careful.
- When lifting the cabinet, be sure to hold the handles and the bottom part. Lifting the cabinet by holding other portions may damage parts and installation portions due to the empty weight of the cabinet, and may cause personal injury.



CAUTION

Do not push the monitor cover or molded parts. This may cause damage to the components, and the pieces may in turn cause injury.

Do not apply pressure to the cabinet's molded parts when moving the cabinet. There is a risk of breaking components and/or causing personal injury. When moving, be sure to use the handles at the upper back end of the cabinet.

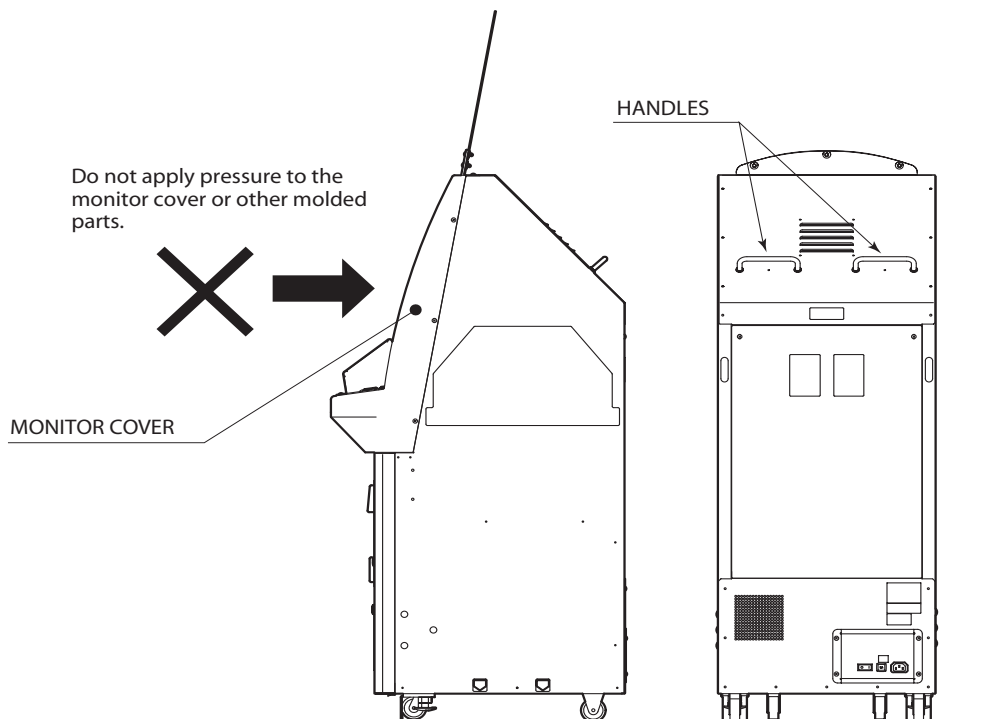

FIG. 8

9. GAME DESCRIPTION

The following explanations apply only if the product is functioning correctly. If anything differs from below, then a problem may have occurred. Immediately look into the cause of the problem and fix it to ensure proper operation.

To draw maximum attention during standby mode, the monitor constantly displays the advertisement (waiting-for-players) screen. This screen, which includes the Mushiking story and game instructions (with sound and BGM), loops repeatedly until coins are inserted. The option of whether or not to play sound during the advertisement screen can be configured in Test Mode settings.

GAME OUTLINE

- A Mushiking Card is dispensed at the beginning of play. When the player scans a Mushiking Card (using the Card Reader), that beetle appears in the game.
- Mushiking Cards are comprised of two types, "Beetle Cards" and "Skill Cards". One "Beetle Card" and up to three "Skill Cards" can be scanned per play. Furthermore, the strength of the beetle will vary depending on the combination of the two card types.
- Both available game types, single-player mode ("One player game") and two-player versus mode ("Play against a friend"), involve battling against another beetle, where the first beetle to eliminate all of the opponent's health is the winner.
- During the countdown to battle, a rock-scissors-paper game determines who will attack.
- The rock ("HIT"), scissors ("PINCH"), and paper ("THROW"), attacks have varying attack power among the different beetles, thus giving an element of strategic planning to the rock-scissors-paper game.



PHOTO 9a



PHOTO 9b

HOW TO PLAY: Game Controls

- (1) Insert coins.
- (2) A Mushiking Card is dispensed. (*)
- (3) The game starts on-screen.
- (4) Scan Mushiking Cards.
- (5) Play a rock-scissors-paper game using the Skill Buttons.

**Note: Mushiking Cards are dispensed randomly. The player cannot choose between Beetle Cards and Skill Cards.*



PHOTO 9c

HOW TO PLAY: Screen Flow

- (1) Insert coins to dispense cards.
- (2) Taking the cards starts the game. Use the corresponding input button to choose either a single-player or a two-player versus game. (Screen 1)

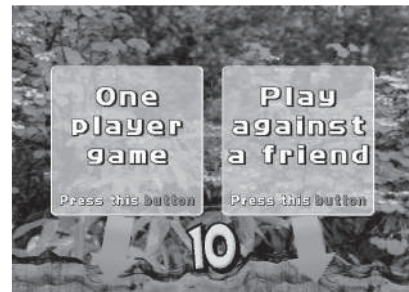

Screen 1

- (3) Choosing single-player lets the player choose a difficulty level. Use the corresponding input button to choose "Easy" or "Hard". (Screen 2)

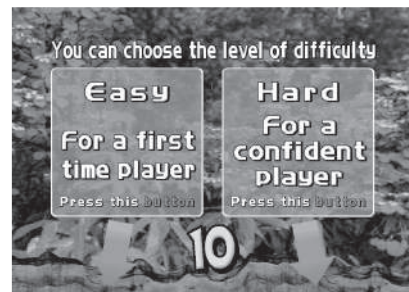

Screen 2

- (4) The screen prompts players to scan a "Beetle Card" (using the Card Reader), allowing them to scan the desired beetle. (Screen 3)

Note: If a "Beetle Card" is not scanned, a substitute beetle will appear in battle and the game will proceed.

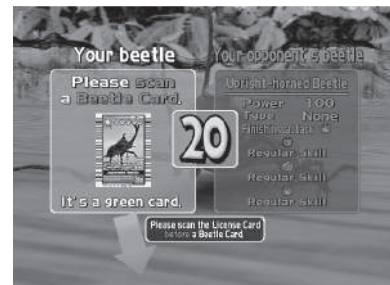

Screen 3

- (5) The screen prompts players to scan "Skill Cards", allowing them to scan desired techniques. (Screen 4)

Note: The game will proceed even if "Skill Cards" are not scanned.

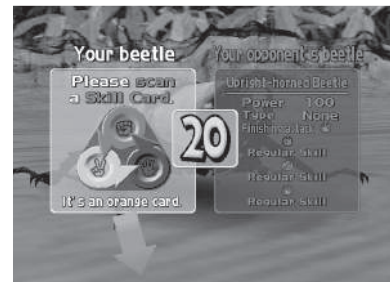

Screen 4

- (6) After completing all card scanning, the degree to which the beetle has been powered up (enhanced attack power) by the applied card combination is displayed. (Screen 5)

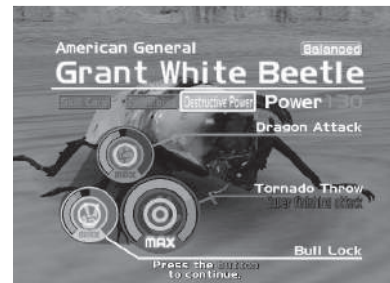

Screen 5

- (7) Before starting the battle, players choose whether or not to receive game instructions. (Screen 6)

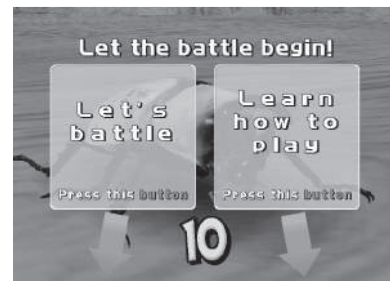

Screen 6

- (8) The battle begins. The player duels with the opponent's beetle in a rock-scissors-paper game by pressing a hand-gesture input button (rock, paper, or scissors) within the battle countdown. (Screen 7)

Note: In single-player mode, a helper character (forest fairy) appears with hints to help the player win.



Screen 7

(9) The winner of the rock-scissors-paper game attacks the opponent with the chosen attack technique. The movement and attack power vary depending on the attack technique. (Screen 8)

- Winning with Rock → Attack with a HIT technique.
- Winning with Scissors → Attack with a PINCH technique.
- Winning with Paper → Attack with a THROW technique.

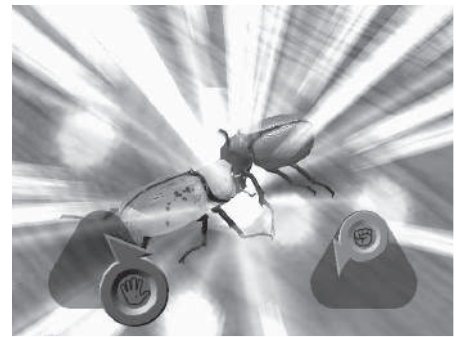

Screen 8

(10) The attacked beetle will lose health. After repeatedly exchanging attacks, the first beetle to eliminate all of its opponent's health is the winner. (Screen 9)



Screen 9

(11) Game Over

- In single-player mode, players can clear the game if they defeat the four opponent beetles from levels 1 to 4. On the other hand, if they are defeated by an opponent beetle during the course of play, this will result in "Game Over". There is no option to "Continue". (Screen 10)



Screen 10

- In two-player mode, each player is granted entry of two beetles, and the winner is the player with the last remaining beetle. (Screen 11)



Screen 11

HOW TO USE MUSHIKING CARDS

- There are two types of Mushiking Cards dispensed, "Beetle Cards" and "Skill Cards".
- Using "Beetle Cards" allows use of the card's beetle in battle.
- Using "Skill Cards" allows the beetle to learn the card's technique and increase the beetle's attack power.
- One of each type of "Skill Card"-Hit, Pinch, and Throw-can be used at the same time for a total of three cards.
- The amount of increased attack power granted to the beetle depends on the combination (compatibility) of "Beetle Cards" and "Skill Cards".
- The greater the "Technique" value of a "Beetle Card", the more likely it is for the beetle to perform techniques with a high degree of difficulty. (They are difficult, but they wield tremendous attack power.)



Beetle Card



Skill Card

10. EXPLANATION OF TEST AND DATA DISPLAY

By operating the TEST and SERVICE Buttons on the maintenance switch unit, periodically perform tests and data check. When installing the machine for the first time, collecting cash, or when the machine does not function correctly, perform a machine check in accordance with the explanations given in this section.

The following shows tests and modes that should be utilized as applicable.

This product's basic system consists of the NAOMI game board. The system enables you to play several games one after the other just by changing a ROM board case that is to be set on the NAOMI case.

The product, therefore, supports the following 2 test modes:

- (1) System test mode for an automatic self-diagnostic test (generally used by every product that contains the basic system) and for a coin assignment (specifically used by this product) and
- (2) Game test mode for testing the input/output control devices and setting the difficulty level (specifically used by this product).

This manual does not cover the automatic self-diagnostic test. For more information about the system test mode, see the attached NAOMI Service Manual.

TABLE 10 EXPLANATION OF TEST MODE

ITEMS	DESCRIPTION	REFERENCE SECTIONS
INSTALLATION OF MACHINE	When the machine is installed, perform the following: 1. Check to ensure each setting is the standard setting at shipment. 2. Check each Input equipment in the INPUT TEST mode. 3. Check each Output equipment in the CARD DISPENSER TEST mode. 4. Test on-IC-Board IC's in the self-test mode.	S/M* & 10-2 10-3 (2), (4) 10-3 (5) S/M*
MEMORY TEST	This test is automatically executed by selecting RAM TEST or ROM BOARD TEST in the Menu mode.	S/M*
PERIODIC SERVICING	Periodically perform the following: 1. Run Memory Test. 2. Ascertain each setting. 3. Test each Input equipment in the INPUT TEST mode. 4. Test each Output equipment in the CARD DISPENSER TEST mode.	S/M* & 10-2 - 10-3 (2), (4) 10-3 (5)
CONTROL SYSTEM	1. Check each Input equipment in the INPUT TEST mode. 2. Adjust or replace each Input equipment. 3. If the problem still persists, check each equipment's mechanism movements.	S/M* & 10-3 10-3 (2), (4), (5) Sections 11, 12, 14
MONITOR (CRT)	In the Monitor Adjustment mode, check to see if Monitor adjustments are appropriate.	S/M* & Section 15
IC BOARD	Memory Test.	S/M*

S/M*: NAOMI Service Manual

10-1 MAINTENANCE SWITCH UNIT AND COIN METER



WARNING

Never touch places other than those specified. Touching places not specified can cause electric shock and short circuit accidents.

STOP IMPORTANT

- Adjust the sound to an optimal level, taking into consideration the environmental requirements of the installation location.
- Removing the Coin Meter circuitry renders the game inoperable.

Maintenance Switch Unit

Open the service door, and the maintenance switch unit shown will appear.

The function of each switch is as follows:

- (1) SOUND VOLUME (VOLUME): Sound volume can be adjusted for the speakers.
- (2) POWER SWITCH (POWER): Switch ON/OFF the power supply.
- (3) DEMAGNETIZER BUTTON (DEMAG): Eliminates the on-screen color unevenness due to magnetization of CRT. Use this switch first before performing the monitor's color adjustment.
- (4) TEST BUTTON (TEST): When operating TEST Button, refer to the following pages.
- (5) SERVICE BUTTON (SERVICE): Gives credits without registering on the coin meter.

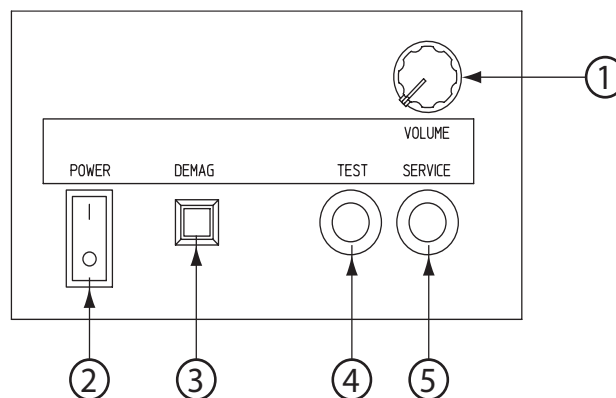
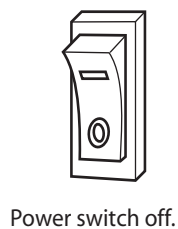

FIG. 10-1a

Coin Meter

The Coin Meter counts the number of coins inserted into the coin slot.

Open the Cashbox Door by using the key to have the Coin Meter appear underneath the Cashbox.

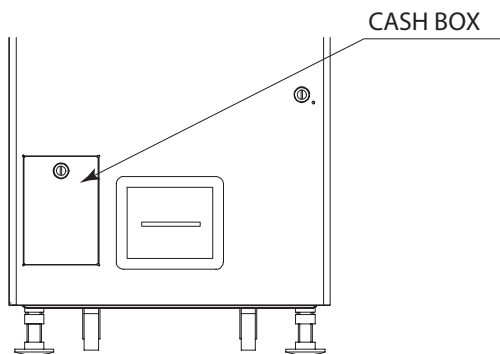

FIG. 10-1b

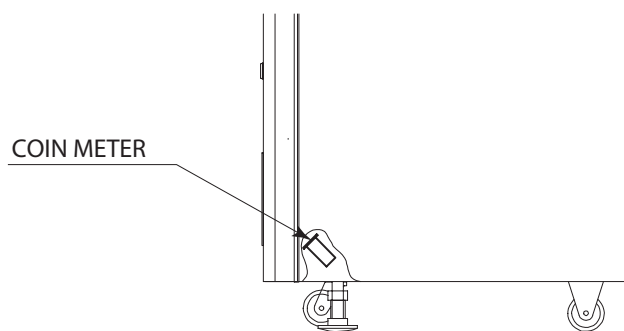

FIG. 10-1c

10-2 SYSTEM TEST MODE

STOP IMPORTANT

- The settings changed in Test Mode are stored when Test Mode is ended using EXIT in the menu mode. If the power is turned off before Test Mode is finished, the setting changes do not take effect.
- Executing BACKUP DATA CLEAR in System Test Mode does not clear the bookkeeping data in Game Test Mode.
- Entering Test Mode clears fractional number of coins less than one credit and bonus added data.

System Test Mode can be used to check IC Board functioning, adjust the monitor, and change coin settings. Refer to the NAOMI Service Manual for details. However, be sure to employ the settings outlined below for this product.

- CABINET TYPE: 1 PLAYER (S)
- MONITOR TYPE: HORIZONTAL
- COIN CHUTE TYPE: COMMON

10-3 GAME TEST MODE

(1) GAME TEST MENU

```

SYSTEM MENU
**** VERSION

RAM TEST
JVS TEST
SOUND TEST
C.R.T TEST
SYSTEM ASSIGNMENTS
COIN ASSIGNMENTS
BOOKKEEPING
BACKUP DATA CLEAR
CLOCK SETTING

ROM BOARD TEST
-> GAME TEST MODE
[MKG TKOB XXXXXX XXXXXXXX]

EXIT

SELECT WITH SERVICE BUTTON
AND
PRESS TEST BUTTON
    
```

SYSTEM TEST MENU Screen



```

GAME TEST MENU

INPUT TEST
C.R.T TEST
BARCODE READER TEST
CARD DIS PENSOR TEST
MANAGEMENT CHIP STATUS
BOOKKEEPING
BACHUP DATA CLEAR

+EXIT

SELECT WITH SERVICE BUTTON
AND PRESS TEST BUTTON
    
```

GAME TEST MENU Screen

(2) INPUT TEST

Select INPUT TEST to display the following screen and check the status of input devices. This test should be run periodically to ensure that each input device is functioning correctly.

```

GAME TEST MODE
INPUT TEST

PLAYER 1P 2P
HIT SWITCH ON OFF ON OFF
PINCH SWITCH ON OFF ON OFF
THROW SWITCH ON OFF ON OFF

SERVICE TEST OFF OFF

PRESS TEST AND SERVICE BUTTON
TO EXIT
    
```

INPUT TEST Screen

Select GAME TEST MODE from the System Test Menu screen to display the Game Test Menu screen as follows.

Use the SERVICE Button to move the cursor to the desired test item. Press the TEST Button to enter the selected item.

After selecting an item, read the explanations below [(2) ~ (8)] regarding operation.

After making changes, be sure to select EXIT and press the TEST Button in order to enable the new settings.

Select EXIT and press the TEST Button to end the Game Test Mode and return to the System Test Menu screen. Select EXIT and press the TEST Button again to end System Test Mode and return to the game screen.



(3) CRT TEST

Select CRT TEST to display the following screen and check the status of the CRT (monitor). This test should be run periodically to check the monitor condition.

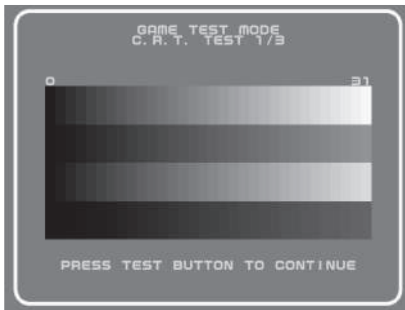

CRT TEST Screen <1/3>



CRT TEST Screen <2/3>

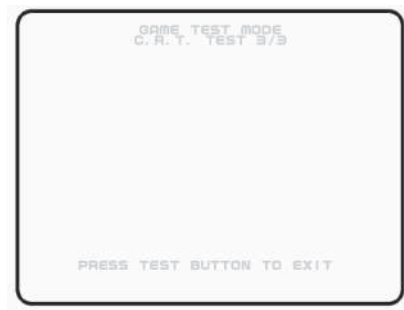

CRT TEST Screen <3/3>

Pressing the TEST Button will display the "Color Bar", "All Black", and "All White" screens in order. Press the TEST Button again to return to the Game Test Menu screen.

Refer to Section 15, "MONITOR", for more information on CRT adjustment.

(4) BARCODE READER TEST

Select BARCODE READER TEST to display the following screen and check the status of the barcode reader. This test should be run periodically to check the condition of the barcode reader.

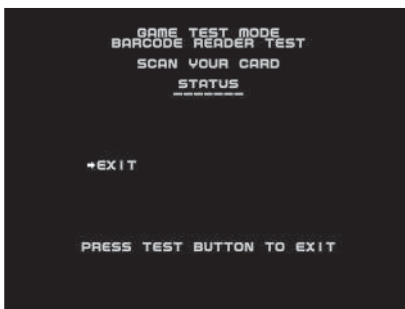

READER TEST Screen

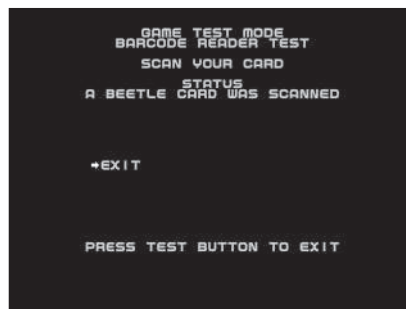

Screen showing a "Beetle Card" scan



Screen showing a "Skill Card" scan

Scan a "Beetle Card" and a "Skill Card". If scanned correctly, a message will be displayed on the screen under STATUS. A failed scan, or scanning cards other than Beetle or Skill cards will result in "-----" to be displayed.

Move the cursor to EXIT and press the TEST Button to return to the Game Test Menu screen.

(5) CARD DISPENSER TEST

Select CARD DISPENSER TEST to display the following screen and check the status of the card dispenser. This test should be run periodically to check the condition of the card dispenser.



CARD DISPENSER TEST Screen

Move the cursor to CARD DISPENSER and press the TEST Button.

Different STATUS messages will be displayed depending on the operation status of the Card Dispenser.

"OK":	It is possible to dispense the card.
"CARD JAMMED":	A card is jammed.
"CARD EMPTY":	There are no cards in the dispenser.
"-----":	There is either no Card Dispenser attached, the dispenser is in the middle of dispensing, or something not listed above has occurred.

Move the cursor to EXIT and press the TEST Button to return to the Game Test Menu screen.

(6) MANAGEMENT CHIP STATUS

Select MANAGEMENT CHIP STATUS to display the following screen and check the status of the management chips.

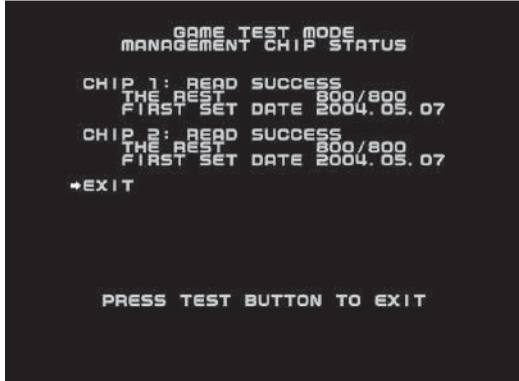

MANAGEMENT CHIP STATUS Screen

If the Management Chip is read correctly, "READ SUCCESS" will be displayed to the right of "CHIP *".

<Other Possible Messages>

"READER NOT READY": There is no Card Reader interface board.

"NOW ACCESS": In the middle of reading data.

"READ ERROR": The read failed.

"UNKNOWN CHIP

FORMAT": The chip code, etc. is wrong.

THE REST:

The number of times remaining on the Management Chip.

"***/**" = Initial Number/Remaining Number

FIRST SET DATE:

Displays the Management Chip's initial date of installation.

Move the cursor to EXIT and press the TEST Button to return to the Game Test Menu screen.

(7) BOOKKEEPING

Select BOOKKEEPING to display the following operating data.



BOOKKEEPING MENU Screen

Use the SERVICE Button to move the cursor to the desired test item. Press the TEST Button to enter the selected item. After selecting an item, read the explanations below [(A) ~ (E)] regarding operation.

Move the cursor to EXIT and press the TEST Button to return to the Game Test Menu screen.

(A) PLAY COUNT

Select PLAY COUNT to see the following screen and view the number of plays.



PLAY COUNT Screen

TOTAL COUNT: Total number of plays.

1PLAY COUNT: Total number of single-player plays.

2PLAY COUNT: Total number of two-player plays.

1P EASY COUNT: Number of single-player EASY Mode plays.

1P HARD COUNT: Number of single-player HARD Mode plays.

TODAY 1PLAY: Number of single-player plays on the current day.

TODAY 2PLAY: Number of two-player plays on the current day.

1P EASY LEVEL CLEAR: Number of single-player EASY Mode game completions.

1P HARD LEVEL CLEAR: Number of single-player HARD Mode game completions.

Move the cursor to EXIT and press the TEST Button to return to the Bookkeeping Menu screen.



(B) TIME HISTOGRAM

Select TIME HISTOGRAM to see the following screen and check the play count for any given day and time.



TIME HISTOGRAM Screen

Select CONTINUE with the SERVICE Button and press the TEST Button to advance to the next screen.

One week of data [7 days (pages)] are saved, constantly overwriting the oldest data first.

Move the cursor to EXIT and press the TEST Button to return to the Bookkeeping Menu screen.

(C) PLAY TIME

Select PLAY TIME to see the following screen and view duration of play.



PLAY TIME Screen

1P AVR: Average single-player play time.
 1P MAX: Longest single-player play time.
 1P MIN: Shortest single-player play time.

2P AVR: Average two-player play time.
 2P MAX: Longest two-player play time.
 2P MIN: Shortest two-player play time.

1P TOTAL PLAY TIME: Total single-player play time.
 2P TOTAL PLAY TIME: Total two-player play time.
 ALL TOTAL PLAY TIME: Total combined play time.

Move the cursor to EXIT and press the TEST Button to return to the Bookkeeping Menu screen.

(D) USED CARD DATA

Select USED CARD DATA to see the following screen and view the number of times each card has been scanned for use in the game.



USED CARD DATA Screen

Select CONTINUE with the SERVICE Button and press the TEST Button to cycle through the pages (1/5, 2/5, ..., 5/5 and back to 1/5).

Move the cursor to EXIT and press the TEST Button to return to the Bookkeeping Menu screen.



Table showing names and cards used in USED CARD DATA.

Table 10-3a

Name	Beetle Card	Japanese Name
GRF	Giraffe Stag-beetle	ギラファノコギリクワガタ
HLS	Hercules Beetle	ヘルクレスオオカブト
GRD	Grand Stag-beetle	グランディスオオクワガタ
CCS	Caucasus Beetle	コーカサスオオカブト
ELP	Elephant Beetle	エレファスゾウカブト
JAS	Japanese Stag-beetle	オオクワガタ
FVH	Five Horned Beetle	ゴホンヅノカブト
HMR	Humorous Stag-beetle	メンガタクワガタ
LTL	Little Stag-beetle	コクワガタ
PRY	Parry Stag-beetle	セアカフタマタクワガタ
AMR	Armor Stag-beetle	ミヤマクワガタ
FLT	Flat Stag-beetle	ヒラタクワガタ
SAW	Saw tooth Stag-beetle	ノコギリクワガタ
DER	Deer Stag-beetle	エレファスホソアカクワガタ
JAB	Japanese Beetle	カブトムシ
TLD	Thailand Five Horned Beetle	タイゴホンヅノカブト
GNT	Grant White Beetle	グラントシロカブト
UPH	Upright-horned Beetle	ノコギリタテヅノカブト
ACT	Actaeon Beetle	アクティオンゾウカブト
PWN	Palawan Stag-beetle	パラワンオオヒラクワガタ
RCR	Rhinoceros Beetle	メンガタカブト
SPS	Specious Stag-beetle	スペキオシスシカクワガタ
NEP	Neptune Beetle	ネプチューンオオカブト
ATL	Atlas Beetle	アトラスオオカブト
FLH	Flat Horned Beetle	ヒルトゥスヘラヅノカブト
RUS	Rusty Beetle	サビイロカブト
YEL	Yellow-winged Stag-beetle	ラコダールツヤクワガタ
CHI	Chilean Stag-beetle	コガシラクワガタ
TRD	Tarandus Stag-beetle	タランドゥスツヤクワガタ
GLD	Golden Stag-beetle	オウゴンオニクワガタ



Table 10-3b

Name	Beetle Card	Japanese Name
BANG	Banging Smash	ガンガンスマッシュ
DRGN	Dragon Attack	ドラゴンアタック
DANG	Dangun	ダンガン
SMSH	Rolling Smash	ローリングスマッシュ
BULL	Bull Lock	ブルロック
CRCH	Rolling Clutch Hold	ローリングクラッチホールド
KING	Kingfisher Hug	カワセミハッグ
CUTR	Running Cutter	ランニングカッター
DRIV	Rolling Driver	ローリングドライバー
SSTH	Sidescrew Throw	サイドスクリュースロー
TRND	Tornado Throw	トルネードスロー
BOMB	Sidelock Bomb	サイドロックボム
DSHA	Daisharin	ダイシャリン
SLEP	Crushing Sleeper Hold	デビルスリーパー
MGUN	Machine Gun Punches	ヒャクレツケン

Table 10-3c

Name	Beetle Card	Japanese Name
DANG	Super Dangun	スーパーダンガン
SMSH	Super Rolling Smash	スーパーローリングスマッシュ
KING	Super Kingfisher Hug	スーパーカワセミハッグ
CUTR	Super Running Cutter	スーパーランニングカッター
TRND	Super Tornado Throw	スーパートルネードスロー
BOMB	Super Sidelock Bomb	スーパーサイドロックボム
DSHA	Super Daisharin	スーパーダイシャリン

Table 10-3d

Name	Beetle Card	Japanese Name
FINSH	Finishing Attack Stopper	必殺ふうじ
LASTPW	Last Resort	最後の力
TIEBRK	The Tie Breaker	あいこやぶり
CONFU	Confusion	必殺よこく
AGITA	Agitation	あせらせ
CHLING	Counter Attack Healing	はんげきかいふく
HLING	Healing	かいふく

(E) DISPENSER DATA

Select DISPENSER DATA to see the following screen and view each Card Dispenser status category.



CARD DISPENSER DATA Screen

CARD PAY OUT COUNT: The number of cards dispensed.
CARD JAMMED COUNT: The number of jammed cards.
CARD EMPTY COUNT: The number of "CARD EMPTY" occurrences.

The number of cards dispensed during Test Mode (Card Dispenser Test) is not included in the count.

Move the cursor to EXIT and press the TEST Button to return to the Bookkeeping Menu screen.

(8) BACKUP DATA CLEAR

Select BACKUP DATA CLEAR to clear the contents of BOOKKEEPING data in the Game Test Mode.

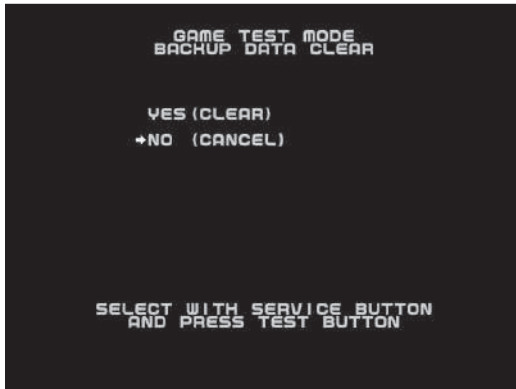

BACKUP DATA CLEAR Screen

To clear data, use the SERVICE Button to move the cursor to YES (CLEAR) and then press the TEST Button. During Data Clear, "COMPLETED" will be blinked to the right of YES. When Data Clear is complete, the "COMPLETED" display will disappear.

Press the TEST Button again to return to the Game Test Menu screen.

Move the cursor to NO (CANCEL) and press the TEST Button to return to the Game Test Menu screen without clearing the data.

11. CARD DISPENSER



WARNING

- When working with the machine, be sure to turn the power off. Working with the power on can cause an electric shock or a short circuit.
- Be careful not to damage the wires. Damaged wires may cause electric shock, short circuit, or present a risk of fire.
- Do not touch undesignated places. Touching these places can cause electric shock or short circuit.
- This work should be performed by the site maintenance individual or another skilled professional. Performing work by non-technical personnel can cause severe accidents such as electric shock.

HOW TO REMOVE THE CARD DISPENSER

1. Turn off the main AC unit power switch and open the service door.

CORD CLAMP

CONNECTOR

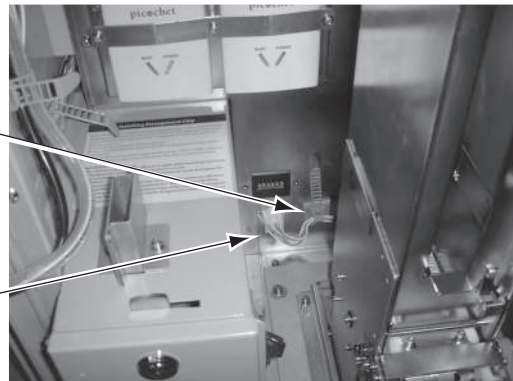

PHOTO 11a

2. Unfasten the cord clamp and connector on the cable connected to the card dispenser, and pull the card dispenser forward while pushing down on the lock lever on the lower section of the card dispenser.

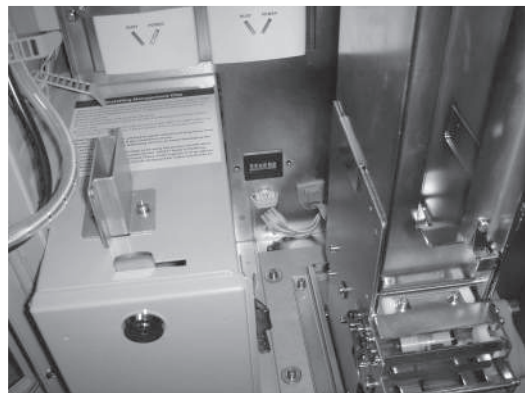

PHOTO 11b

3. When it cannot be pulled forward any further, lift up on the card dispenser and detach it from the rail.

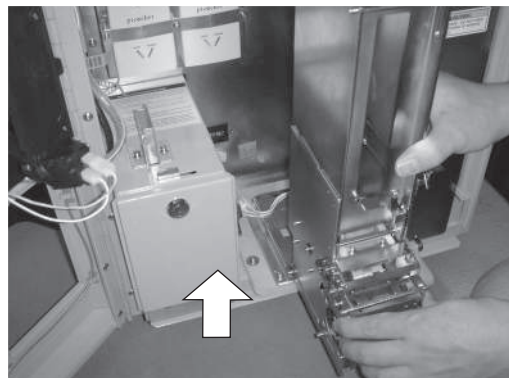

PHOTO 11c

12. CARD READER (CONTROL PANEL)



CAUTION

- When cleaning the card reader, always use the designated Cleaning Card.
- Do not use chemical detergents such as "glass cleaner" available on the market or solvents such as thinner, etc.

12-1 HOW TO CLEAN THE CARD READER

1. Insert the Cleaning Card, aligning the cloth side with the red light in the Card Reader groove.

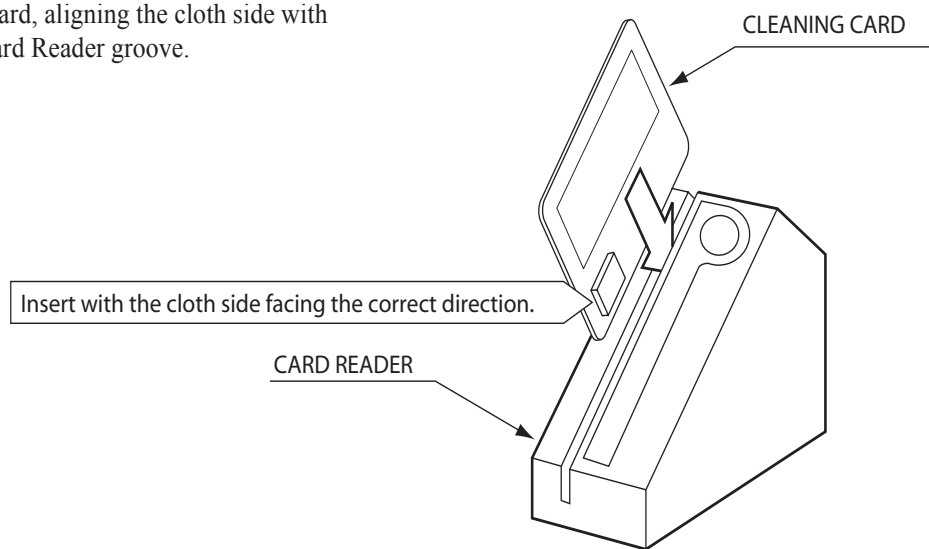

FIG. 12-1a

2. Slowly slide the Cleaning Card up and down to clean off any accumulated dirt.

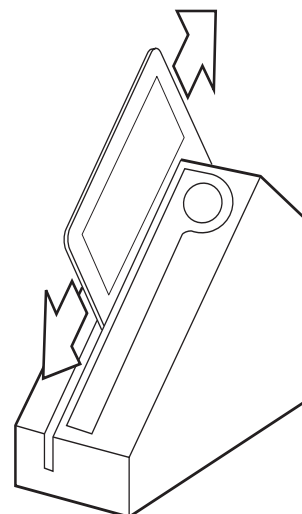

FIG. 12-1b

After cleaning, refer to "10-3 Game Test Mode, (4) Barcode Reader Test" to test the functionality.

12-2 HOW TO REMOVE THE CARD READER



WARNING

- When working with the machine, be sure to turn the power off. Working with the power on can cause an electric shock or a short circuit.
- Be careful not to damage the wires. Damaged wires may cause electric shock, short circuit, or present a risk of fire.
- Do not touch undesignated places. Touching these places can cause electric shock or short circuit.
- This work should be performed by the site maintenance individual or another skilled professional. Performing work by non-technical personnel can cause severe accidents such as electric shock.

1. Turn off the main AC unit power switch.
2. Remove the 8 truss screws on the control panel.

TRUSS SCREW (8), chrome
M4 x 12

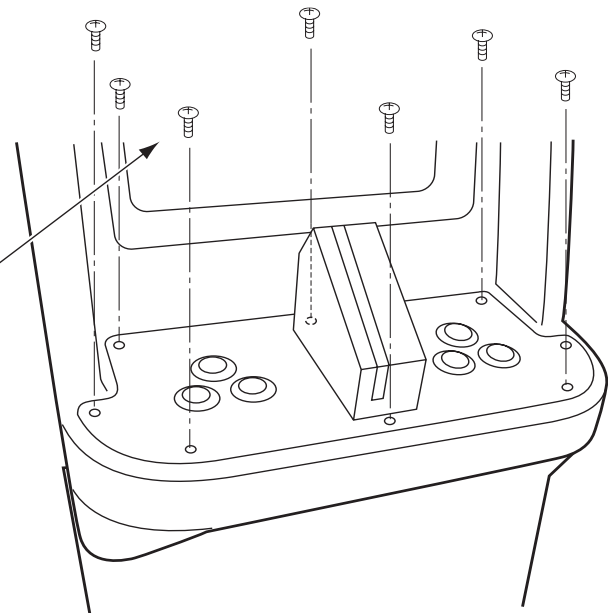

FIG. 12-2

3. Being careful not to damage the cord, unplug the connector from the control panel and pull it out of the cabinet.

CONNECTOR

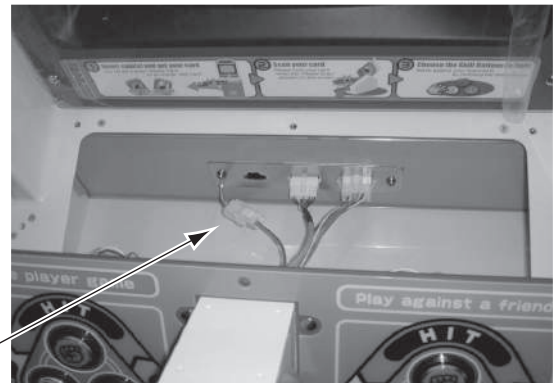

PHOTO 12-2a

- Remove the cord clamp and use nippers to cut the 2 tie belts loose.

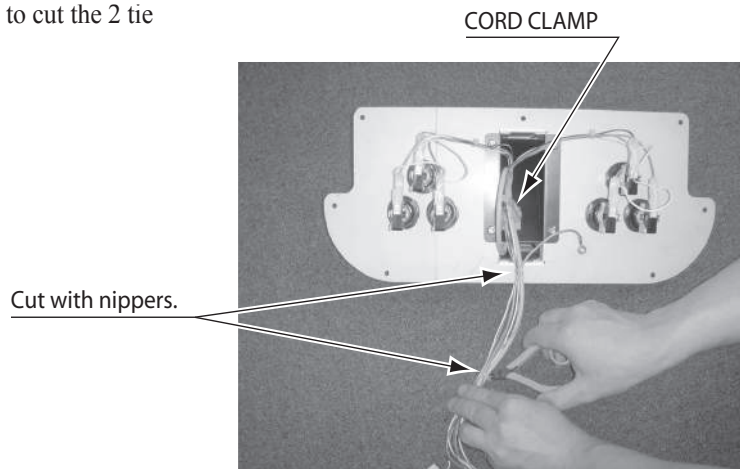

PHOTO 12-2b

- Unfasten the 4 carriage bolts and 4 flange nuts holding the card reader bracket in place and remove the card reader from the control panel.

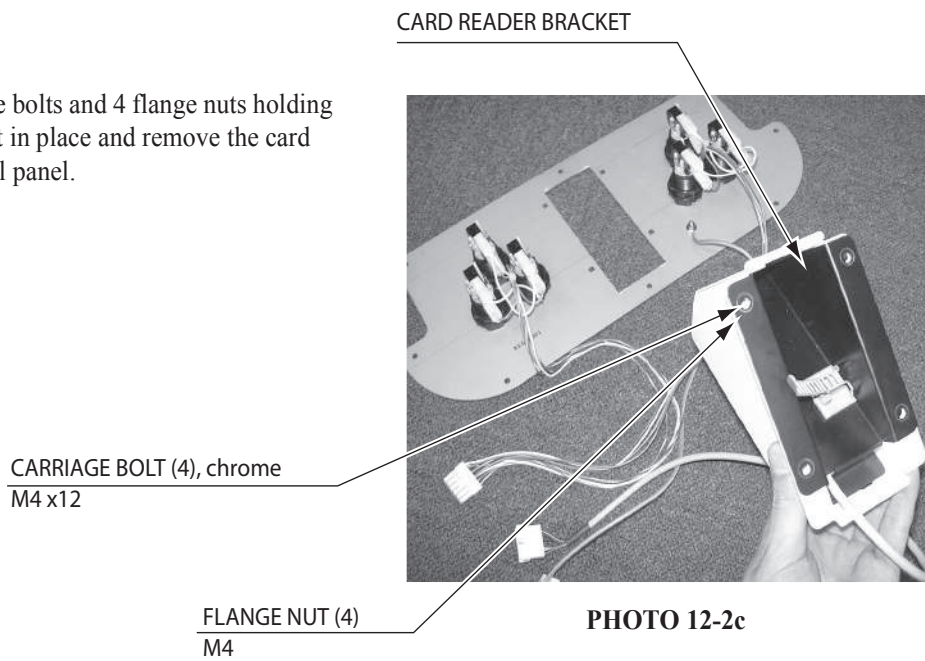

PHOTO 12-2c

- Remove the card reader cover and detach the card reader from the card reader bracket.

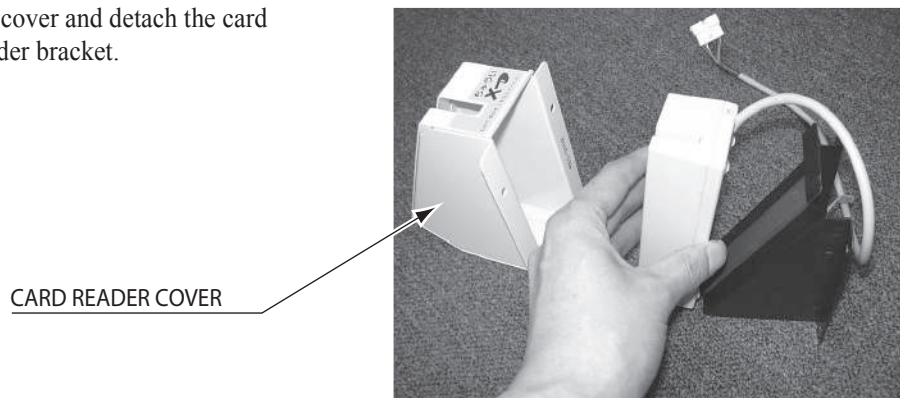

PHOTO 12-2d

12

CARD READER (CONTROL PANEL)

13. POWER & I/O BOARD UNIT



WARNING

- When working with the machine, be sure to turn the power off. Working with the power on can cause an electric shock or a short circuit.
- Be careful not to damage the wires. Damaged wires may cause electric shock, short circuit, or present a risk of fire.
- Do not touch undesignated places. Touching these places can cause electric shock or short circuit.
- This work should be performed by the site maintenance individual or another skilled professional. Performing work by non-technical personnel can cause severe accidents such as electric shock.

13-1 HOW TO REMOVE THE POWER & I/O BOARD UNIT

1. Turn off the main AC unit power switch.
2. Remove the 2 tamperproof screws and detach the back door.

TAMPERPROOF SCREW (2), chrome
M4 x 8

BACK DOOR

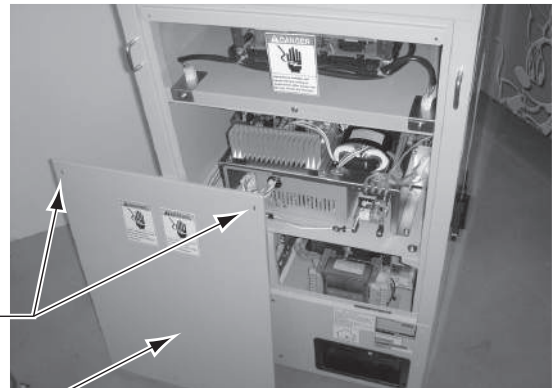

PHOTO 13-1a

3. Unplug all the connectors plugged into the Power & I/O Board unit.

Front 9 points

Rear 3 points

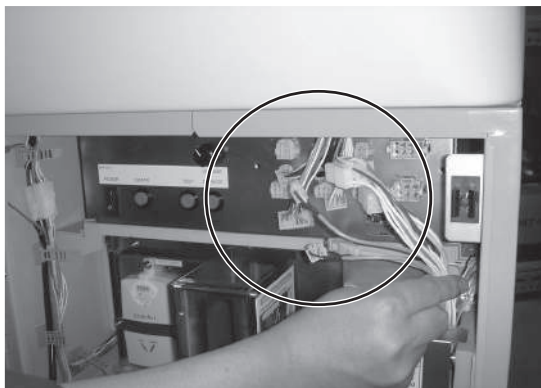

PHOTO 13-1b

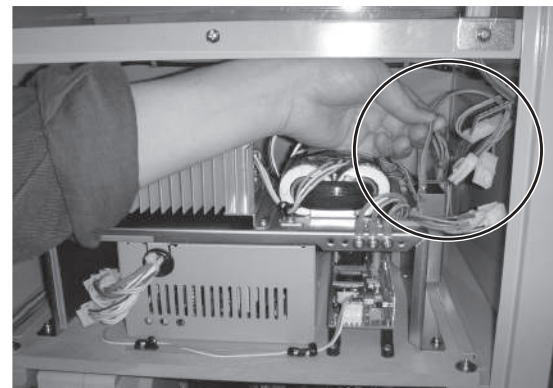

PHOTO 13-1c

4. Remove the 2 wing bolts and pull out the board.

SCREW (2)
M4 x 20, w/flat &
spring washers +
flat washer
(4.4-16 x 1.6)

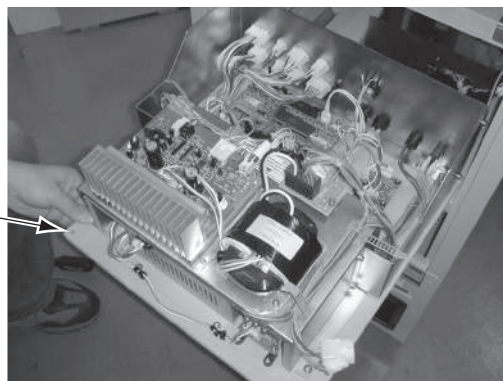

PHOTO 13-1d

13-2 COMPOSITION OF THE POWER & I/O BOARD UNIT

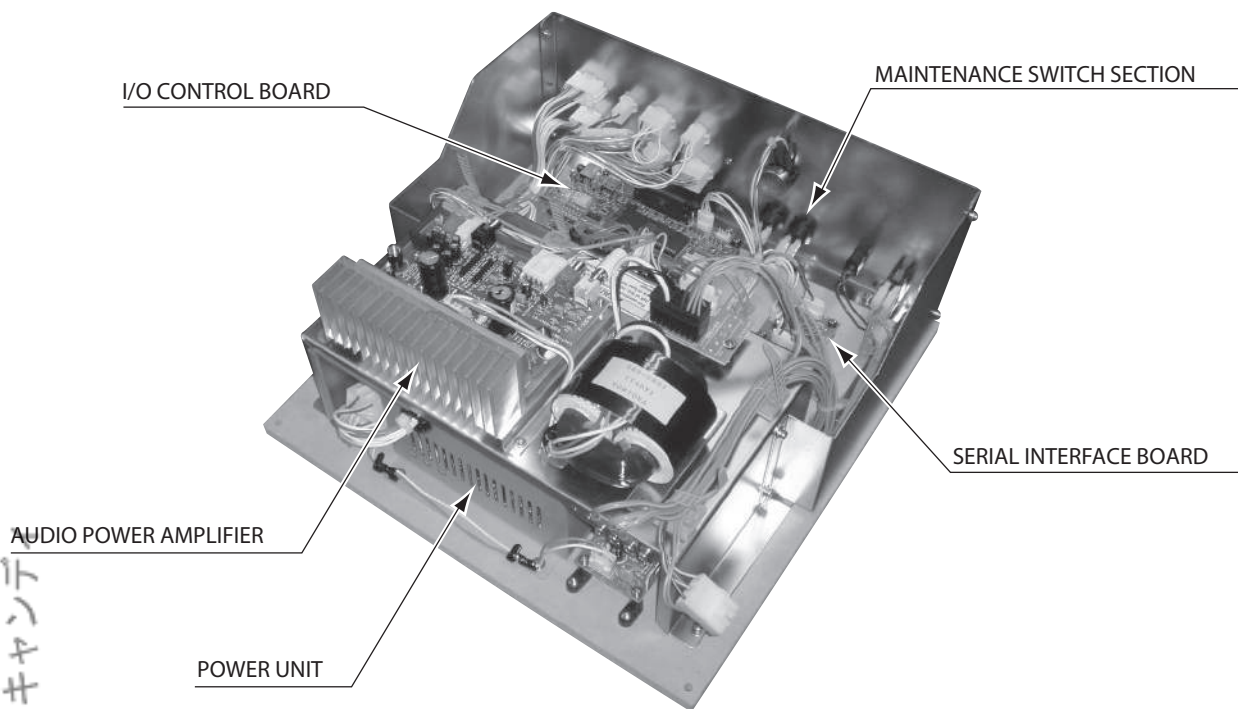

PHOTO 13-2

13

POWER & I/O BOARD UNIT

14. COIN SELECTOR

REMOVING THE COIN SELECTOR

Loosen the plastic-head screw to raise the lever and open the coin selector cover and then remove the coin selector.

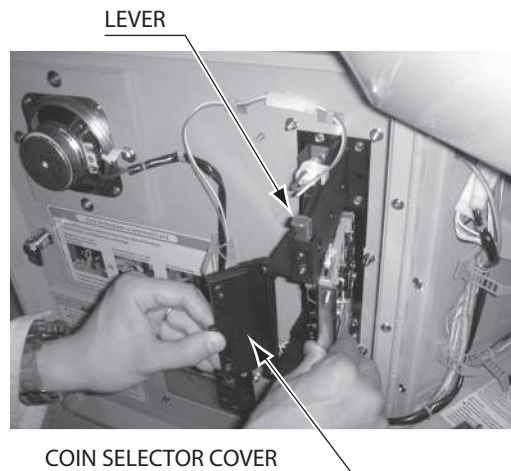

PHOTO 14

REMOVING A JAMMED COIN

When the coin return button fails to refund coins, open the coin chute door and open the selector gate. Once the jammed coin is removed, insert a standard coin to ensure that the selector is working properly.

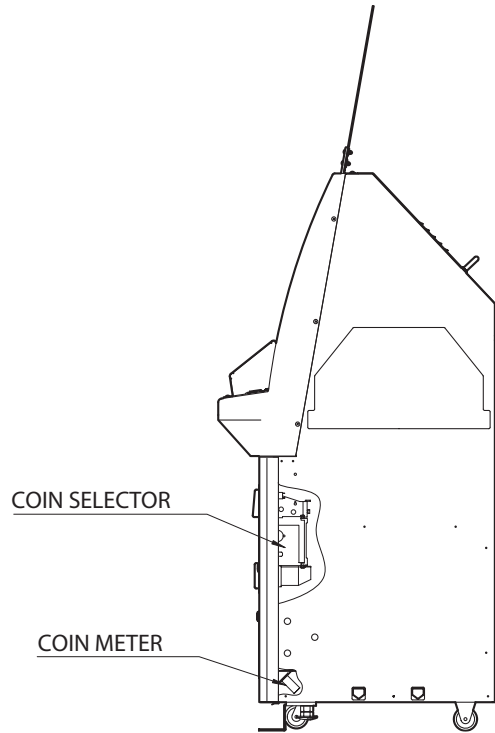

FIG. 14a

CLEANING THE COIN SELECTOR

STOP

IMPORTANT

- Remove and clean smears using a soft cloth dipped in water or diluted chemical detergent and then wrung dry.
- Never apply machine oil, etc. to the coin selector.
- After cleaning the coin selector, properly insert a standard coin to ensure that the selector functions correctly.



The coin selector should be cleaned once every 3 months.
When cleaning, follow the procedures below:

1. Turn off the main AC unit power switch and open the coin chute door.
2. Open the gate and remove dust using a soft brush (made of wool, etc.).
3. Remove and clean smears by using a soft cloth dipped in water or diluted chemical detergent and then wrung dry.
4. Remove the cradle. When detaching the retaining ring (E ring), be extra careful not to bend the rotational axis.
5. Use a soft cloth to wipe any dirt/debris off the rotational axis and bearings.
6. After wiping as described in the previous step, use a dry cloth, etc. to dry the coin selector completely.

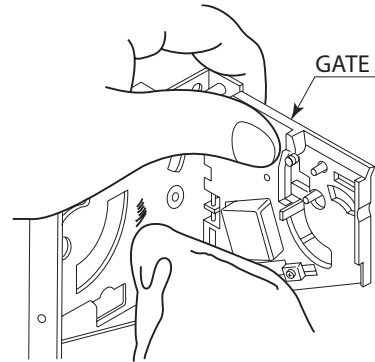

FIG. 14b

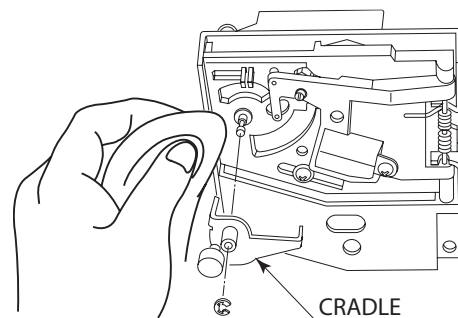

FIG. 14c

COIN INSERTION TEST

Once every month, when performing the Coin Switch Test, check the following points:

- Does the Coin Meter count properly?
- Do coins drop into the Cashbox correctly?
- Are coins rejected when inserted while holding down the Reject Button?

15. MONITOR

15-1 CAUTIONS/WARNINGS REGARDING SAFETY FOR HANDLING THE MONITOR

Before handling the monitor, be sure to read the following points and comply with the caution/warning instructions given below. Note the caution/warning symbols and letters used in the instructions.

WARNING

Indicates that handling the monitors improperly by disregarding this warning may potentially cause a hazardous situation, which could result in death or serious injury.

CAUTION

Indicates that handling the monitors improperly by disregarding this warning may potentially cause a hazardous situation, which could result in death or serious injury.



Indicates that access to a specific part of the equipment is forbidden.



Indicates the instruction to disconnect or unplug a power connector.

WARNING

- When performing such work as installing and removing the monitor, inserting and disconnecting the external connectors to and from the monitor interior and the monitor itself, be sure to disconnect the power connector (plug) beforehand. Proceeding without doing so can cause electric shock or malfunctioning.
- Use of the monitor by converting it without permission is not allowed. SEGA shall not be liable for any malfunctioning and accidents caused by such a conversion.

WARNING

- Primary side and Secondary side
The monitor's circuit, which is divided into the Primary side and Secondary side, is electrically isolated. Do not touch the Primary side, or touch both the primary side and the secondary side simultaneously. Failing to observe this instruction can cause electric shock, leading to serious danger. When making monitor adjustments, use a non-conductive driver and make them without touching any part other than the Adjustment V. R. and knob. Also, be sure not to cause a short circuit to the Primary side and Secondary side. If a short circuit occurs, it can cause electric shock or malfunctioning, which poses a serious risk of danger.

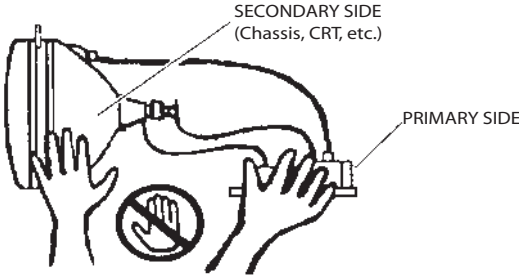

SECONDARY SIDE
(Chassis, CRT, etc.)

PRIMARY SIDE



WARNING

- High Voltage

Some of the parts inside the monitor are subject to high voltage in excess of 20,000 volts and pose a serious threat. Therefore, do not touch the monitor interior. Should soldering & paper wastes, etc. be mixed in the monitor interior, turn the power off so as not to cause malfunctioning or a fire hazard.

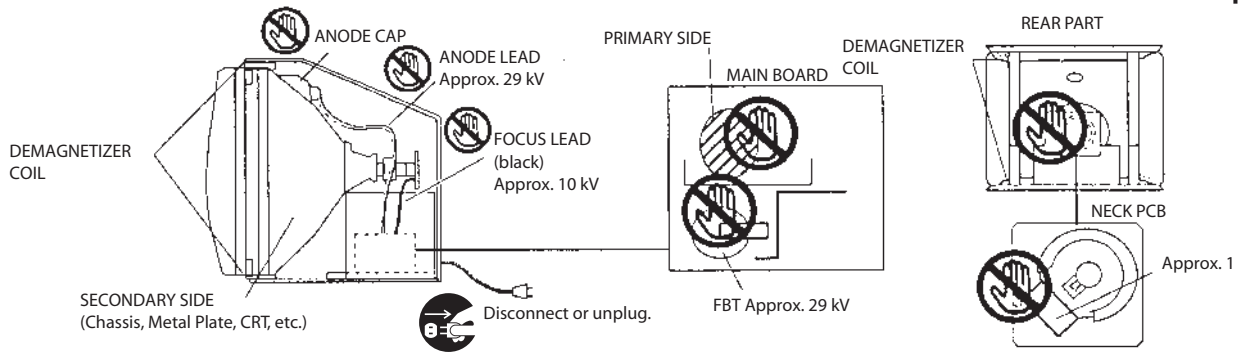

- Connecting the CRT and PCB

When combining the CRT and PCB, use the specified part No. to maintain the factory settings. The anode of the CRT itself will charge as time elapses, generating high voltage that is very dangerous. The monitor should be used with the Chassis, CRT, and PCB assembled. When repair, etc. is required at the time of malfunctioning, be sure to send it in an assembled state. If it is disassembled, the charged high voltage can be released, causing a very hazardous situation. Therefore, under no circumstances should it be disassembled.



CAUTION

- Static Electricity

Touching the CRT surface sometimes causes a slight shock. This is because the CRT surfaces are subject to static and will not adversely affect the human body.

- Installation and Removal

Ensure that the Demagnetizer Coil, FBT (Fly-Back Transformer), Anode Lead, and Focus Lead are not positioned close to the sheet metal work's sharp edges, etc. and avoid damaging the insulated portions so as not to cause electric shock and malfunctioning. (For the name of parts, refer to the figures above.)

15-2 CLEANING THE CRT SURFACES AND THE MONITOR COVER



CAUTION

Observe the following points to prevent damage when cleaning accessory surfaces.

- Remove smears using a dry, soft cloth (flannel, etc.). Do not use coarse gauze or other harsh materials.
- For smear removing solvent, alcohol (ethanol) is recommended. When using chemical detergent, be sure to follow the instructions below:
- Soak a soft cloth in a neutral household detergent diluted with water. Wring the cloth well, and then clean down the surface.
- Do not use bleach or detergent that contains abrasive agents.
- Do not use alkaline chemical detergents such as "glass cleaner" available on the market or solvents such as thinner, etc.
- Do not scrape or scratch surfaces using brushes, scouring pads, or other hard cleaning utensils.

Clean the CRT surface and the monitor cover once a week. Apply antistat after cleaning.

1. Turn off the main AC unit power switch.
2. Remove the 7 truss screws and detach the monitor cover.
3. The monitor (CRT) will be exposed. Use an untreated soft cloth to wipe off both the CRT surface and the monitor cover.
4. After cleaning, spray antistat onto the CRT and the monitor side of the monitor cover.

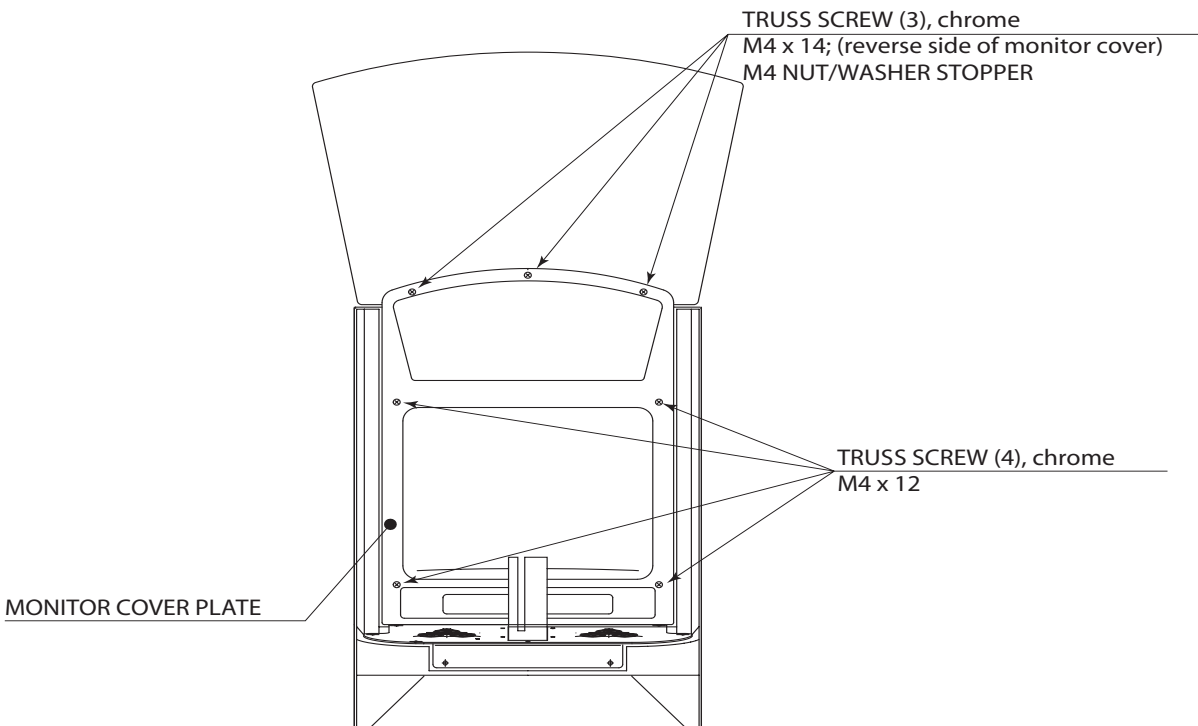

FIG. 15-2

15-3 MONITOR ADJUSTMENT



WARNING

- Monitor adjustments have been made at the time of shipment. Therefore, do not make further adjustments without a justifiable reason. Adjusting the monitor containing high-tension parts is dangerous. Also, an improper adjustment can cause deviated synchronization and image fault, resulting in malfunctioning.
- When making monitor adjustments, use a resin regulating rod. Using bare hands or conductive tools can cause electrocution.
- Be sure to perform appropriate adjustments of the monitor. When operating this machine, do not leave the monitor's flickering or deviation unchecked. Failure to observe this can worsen the players' or the customers' physical conditions.
- Do not touch undesignated places. They can cause electric shock or short circuit.

The monitor regulation board is located on the lower part of the monitor.

DESCRIPTION OF ADJUSTMENT KNOBS

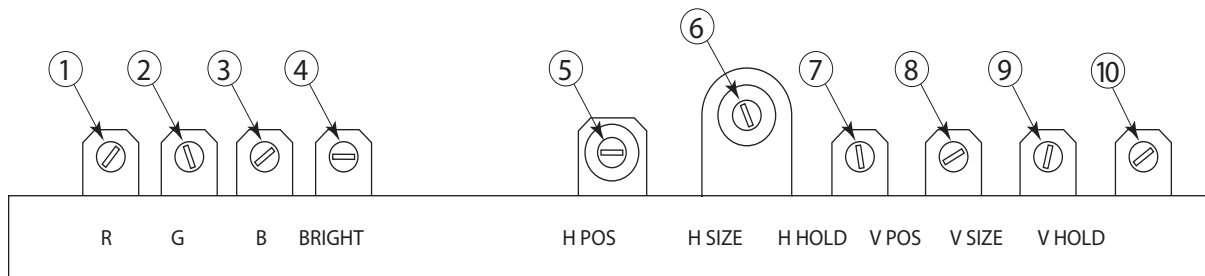

FIG. 15-3a

- (1) R. GAIN: } Adjusts each VR to get a suitable contrast and white balance.
 (2) G. GAIN: }
 (3) B. GAIN: }
- (4) BRIGHT: Adjusts screen brightness.
- (5) H POSI: Adjusts horizontal positioning of screen.
- (6) H SIZE: Adjusts horizontal screen dimension.
- (7) H HOLD: Adjusts horizontal scrolling of screen.
- (8) V POSI: Adjusts vertical positioning of screen.
- (9) V SIZE: Adjusts vertical screen dimension.
- (10) V HOLD: Adjusts vertical scrolling of screen.

HOW TO CONFIRM ADJUSTMENTS

1. Enter TEST MODE and select GAME TEST MODE by positioning the cursor and pressing the TEST Button.

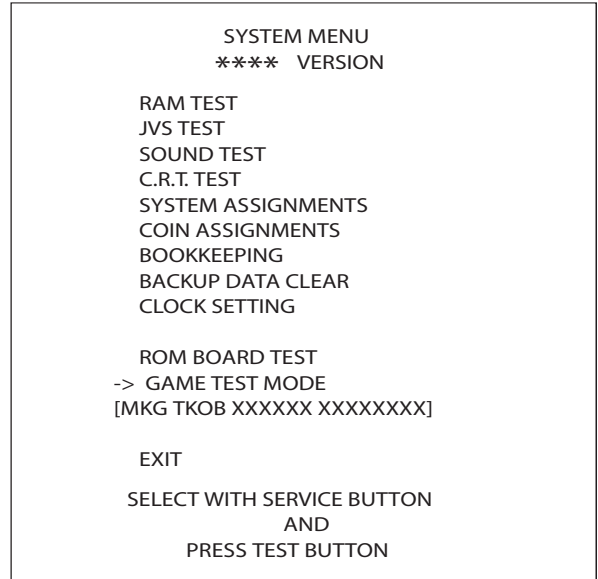

FIG. 15-3b SYSTEM TEST MODE Screen

2. Position the cursor with CRT TEST and press the TEST Button to display the CRT TEST screen.



PHOTO 15-3a GAME TEST MENU Screen

The white frame is visible all around the screen.

The black portion of the image is not entirely visible around the screen.

The 31st color gradation is set to be faintly visible. (The 32nd gradation for each color is black.)

The top 2 gradations are set at the same level. (No gradation difference.)

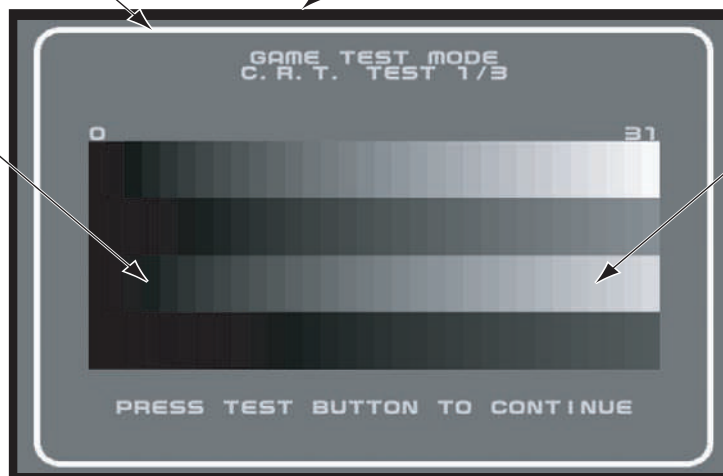

PHOTO 15-3b CRT TEST Screen

16. PERIODIC INSPECTION

The items listed below require periodic check and maintenance to retain the performance of this machine and to ensure safe business operation.



WARNING

- Be sure to check once a year to see whether Power Cords are damaged, the plug is securely inserted, dust has accumulated between the Socket Outlet and the Power Plug, etc. Using the product with accumulated dust can cause fire and electric shock.
- Never use a water jet, etc. to clean inside and outside the cabinet. If the machine gets wet for any reason, do not use it until it has completely dried.
- Periodically, around once a year, get in touch with the place of contact herein stated or the Distributor, etc. where the product was purchased from, regarding internal cleaning. Using the product with accumulated dust in the interior can cause a fire or accident. Note that professional cleaning will require a fee.

TABLE 16 PERIODIC INSPECTION TABLE

ITEMS	DESCRIPTION	PERIOD	REFERENCE
CABINET	Checking Adjusters/Hold Brackets grounding	Daily - before opening hours	3
MONITOR	Screen Cleaning	Biweekly	15
	Check adjustments.	Monthly	15
GAME BOARD	Check settings.	Monthly	10
CARD READER	Head Cleaning	Monthly	12
SPEAKERS/SOUND	Sound Test, Check sound volume adjustment.	Monthly	10
COIN SELECTOR	Coin Insertion Test	Monthly	14
	Cleaning	Tri-monthly	14
POWER SUPPLY PLUG	Inspection and Cleaning	Annually	See above.
INTERIOR	Cleaning	Annually	See above.
CABINET SURFACES	Cleaning	As necessary	Next Page

CLEANING THE CABINET SURFACES

When the cabinet surfaces become dirty, remove stains with a soft cloth soaked in water or diluted (with water) chemical detergent and then wrung dry. To avoid damaging the finish, do not use such solvents as thinner, benzene, etc. (other than ethyl alcohol) or abrasives (bleaching agent and chemical dust-cloth).

Some general-purpose household, kitchen, and furniture cleaning products may contain strong solvents that degrade plastic components, coatings, and print. Before using any cleaning product, read the product's cautionary notes carefully and test the product first on a small area that is not highly visible.



WWW.HARD--CANDY.COM
ハート

17. TROUBLESHOOTING



WARNING

- In order to prevent electric shock and short circuit, be sure to turn power off before working on the machine.
- Be careful not to damage wiring. Damaged wiring may cause electric shock or short circuit.
- After fixing the problems regarding the Circuit Protector, reinstate the Circuit Protector. Depending on the cause of the problem, using the Circuit Protector without addressing the malfunction can generate heat and can present a fire hazard.
- In the event that a problem cannot be resolved by employing the procedures listed in this manual, be sure to request service from the office shown on this manual or the dealer from whom the product was originally purchased. Attempts to employ procedures other than those specified in this manual can cause electrical shock, shorting, or fire.



IMPORTANT

If a problem occurs, first check to make sure that the wiring connectors are properly connected.

TABLE 17a TROUBLESHOOTING TABLE

PROBLEMS	CAUSE	COUNTERMEASURES
Turning on the power switch fails to power on the machine.	The power is not ON.	Firmly insert the power plug into the outlet.
	Either the main switch or the power switch is turned off.	Turn on both the main switch and the power switch.
	Incorrect power source/voltage.	Make sure that the power supply/voltage is correct.
	The Circuit Protector malfunctions due to a power surge.	After eliminating the cause of the power surge, restore the Circuit Protector of the AC Unit. (See next page.)
Sound is not emitted.	Sound volume adjustment is not correct.	Adjust the switch unit's sound adjustment volume control.
	Sound-related circuit malfunction.	Perform SOUND TEST.
Cards are not dispensed.	Cards are empty.	Refill cards.
	Card jam.	Remove the jammed card(s).
	The connector is not connected properly.	Ensure proper connection.
	Card dispenser malfunction.	Exchange the card dispenser.
Cannot scan (read) cards.	Card reader card slot is dirty.	Use the attached cleaning card to clean the card slot.
	The connector is not connected properly.	Ensure proper connection.
	Card reader malfunction.	Exchange the card reader.

HARD CANDY
 WWW.HARD-CANDY.COM
 ハードキャンディ

TABLE 17b TROUBLESHOOTING TABLE

PROBLEMS	CAUSE	COUNTERMEASURES
Cannot enter TEST MODE.	Switch malfunction.	Exchange the switch.
	Game Board abnormality.	Exchange the Game Board.
	The operation used to change to TEST MODE is incorrect.	Ensure correct operation.
Monitor display is abnormal.	Game Board and monitor connection failure.	Ensure proper connection (of connector).
	Monitor malfunction.	Exchange the monitor.
	Game Board malfunction.	Exchange the Game Board.
There is no response from control panel buttons.	Button failure.	Exchange the button(s).
	The connector is not connected properly.	Ensure proper connection.
	Not set to game mode.	Change setting to game mode.

CIRCUIT PROTECTOR

The Circuit Protector uses a bimetal to break the circuit. Due to the heat, the machine cannot be restarted until it cools. Wait at least 1 minute before restarting. (Press the button in.)

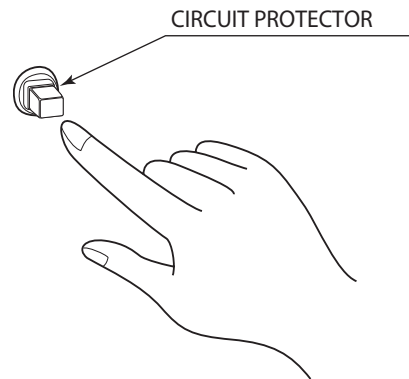

FIG. 17

18. GAME BOARD



WARNING

- In order to prevent electric shock and short circuit, be sure to turn power off before working on the machine.
- Be careful not to damage wiring. Damaged wiring may cause electric shock or short circuit.
- Do not expose the Game Board, etc. for no reason. Failure to observe this can cause electric shock or malfunctioning.



CAUTION

- There is no need to handle the Game Board for this machine since all setting changes are done in TEST MODE. Failure to use the Game Board or any other IC board as shipped can cause electric shock or malfunctioning.
- The chip components on IC boards can be damaged by electrostatic discharge from the human body. Before handling an IC board, always neutralize any static charge in the body by touching a grounded metal surface.

18-1 REMOVING THE GAME BOARD

This machine uses the NAOMI Board. When submitting for exchange or repair, remove the ASSY MAIN BOARD from the cabinet and detach the NAOMI board according to the following procedures.

1. Turn off the main AC unit power switch and open the service door.
2. Loosen the 2 truss screws and detach the NAOMI cover.

NAOMI COVER

TRUSS SCREW (2), chrome
M4 x 8

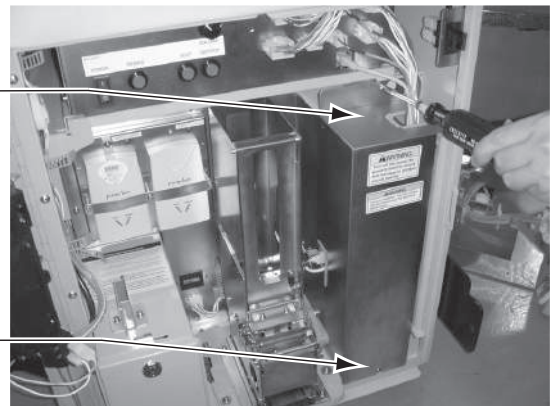
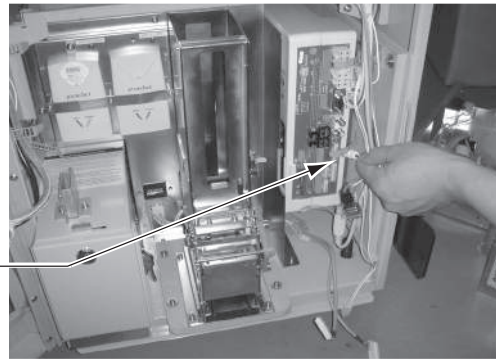

PHOTO 18-1a

3. Unplug all the connectors joined to the NAOMI board.



CONNECTOR (total 9)

PHOTO 18-1b

4. Remove the 1 wing bolt and pull out the ASSY MAIN BD.

SCREW (1)
M4 x 20, w/flat &
spring washers +
flat washer
(4.4-16 x 1.6)

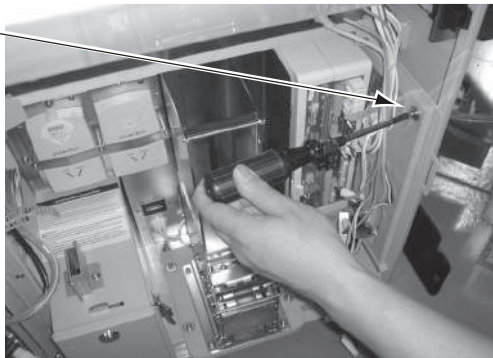

PHOTO 18-1c



PHOTO 18-1d

5. Remove the 4 screws and detach the NAOMI board from the base.

SCREW (4)
M4 x 12, w/flat & spring washers

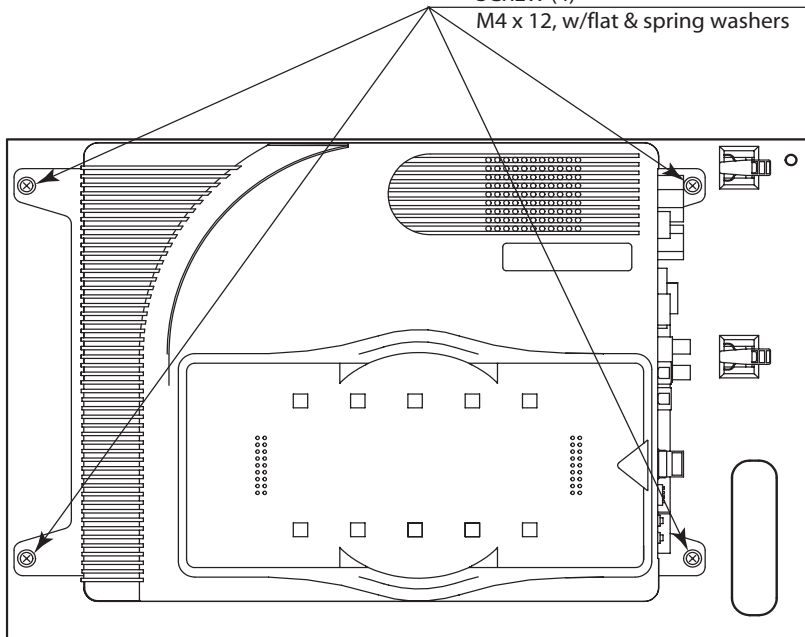

FIG. 18-1

When submitting for exchange or repair, wrap the NAOMI Board (with the ROM Board still mounted) in packing materials and submit in a carton box. (See Section 5.)

18-2 COMPOSITION OF THE GAME BOARD

STOP IMPORTANT

Use the Filter Board DIP SW only with the advised settings. Use with different settings may cause the screen to display improperly or other malfunctions.

- ASSY CASE NAO MKG 2K3 2ND USA (840-0150D-01): USA
- ASSY CASE NAO MKG 2K3 2ND EXP (840-0150D-02): OTHERS
- ASSY CASE NAO MKG 2K3 2ND KOR (840-0150D-03): KOREA
- ASSY CASE NAO MKG 2K3 2ND AUS (840-0150D-04): AUSTRALIA

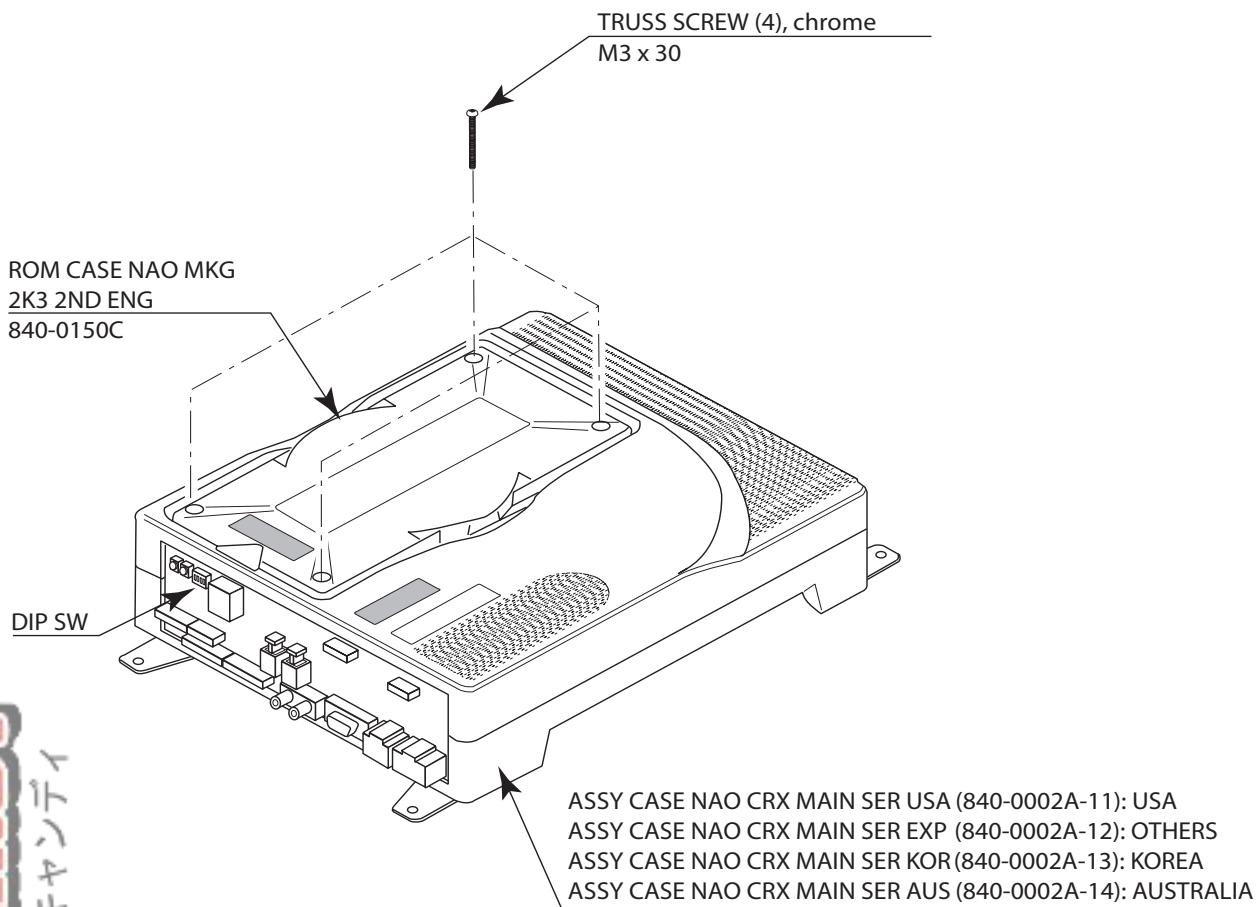

FIG. 18-2a

DIP SW Setting

Use this product with the DIP SW settings shown in the figure below.

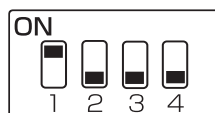

FIG. 18-2b

CANDY
 キャンディ
 WWW.HARD-CANDY.COM
HARD
 ハード

19. DESIGN-RELATED PARTS

For the Warning Display Stickers, refer to Section 1.

POP MUSHI ENG
MKG-0009-01

DISPLAY SHEET MUSHI ENG
MKG-0007-01

PLAY INSTR SHEET MUSHI ENG
MKG-0008-01

STICKER CTRL PANEL MUSHI ENG
MKG-2004-02

STICKER BARCORD RDR CASE ENG
MKG-2005-01

STICKER PICOUT CARD MUSHI ENG
MKG-0005-01

STICKER CABI SIDE MUSHI ENG (Both sides)
MKG-0006-01

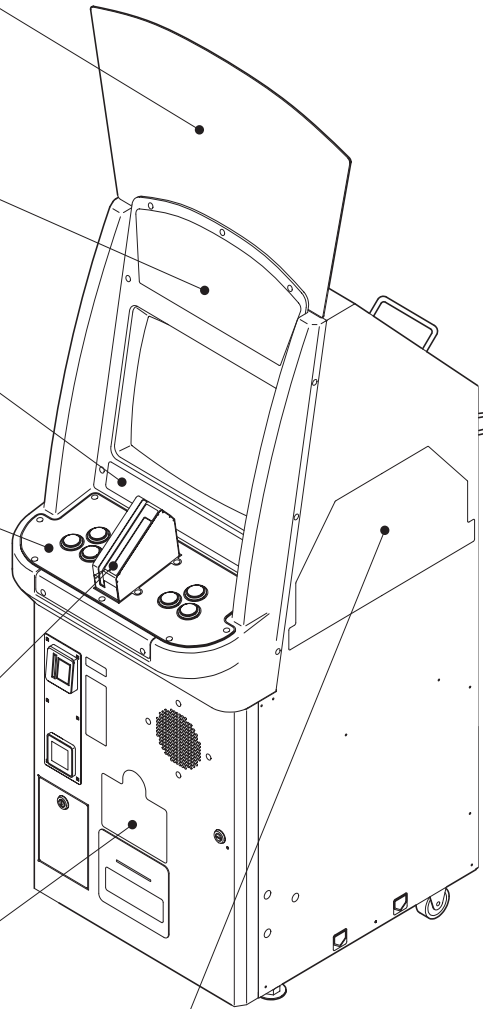

20. PARTS LIST

[A] TOP ASSY MKG 2K3 2ND EXP OEM
MKG-0004

[1] TOP ASSY MKC EXP CABI OEM
MKC-0000-01

[2] ASSY CASE NAO MKG 2K3 2ND EXP
840-0150D-02

(1) TOP ASSY MKC EXP CABI OEM
MKC-0000-01

(2) ASSY CARD DISPENSER EXP
MKG-0500-01

(3) ASSY SLIDER
MKG-0550

(4) ASSY RFID CHIP R/W
MKG-0600

(5) ASSY CABINET MKC EXP
MKC-1000-01

(6) ASSY CABINET BLANK MKC EX P
MKC-1100-01

(7) ASSY DOOR MKC EXP
MKC-1200-01

(8) ASSY COUNTER BRKT EXP
MKG-1300-01

(9) ASSY CASH BOX MKC EXP
MKC-1400-01

(10) ASSY SLIDE BASE MKC EXP
MKC-1500-01

(11) ASSY MONITOR MKC EXP
MKC-1600-01

(12) ASSY FRONT MASK MKC
MKC-1700

(13) AC UNIT EXP
MKG-4100-01

(14) ASSY NAOMI BASE MKC EXP
MKC-4300-01

(15) ASSY XFMR
MKG-4400

(16) ASSY WIRE CABINET DC EXP
MKC-6001-01

(17) ASSY CTRL PANEL MKC EXP
MKC-2000-01

(18) ASSY ELEC BASE MKC EXP
MKC-4200-01





U.K. Unit



U.S. Unit

1

2

3

4

<u>Item No.</u>	<u>Part No.</u>	<u>Description</u>	<u>Comments</u>
1	999-2188	Dollar Bill Acceptor Unit	U.S. Only
2	999-2189	Denomination Plate	
3	999-2190	Lock Bar	U.K. Only (special order only)
4	999-2191	Pedestal	Optional (special order only)

[A] TOP ASSY MKG 2K3 2ND EXP OEM (MKG-00004)

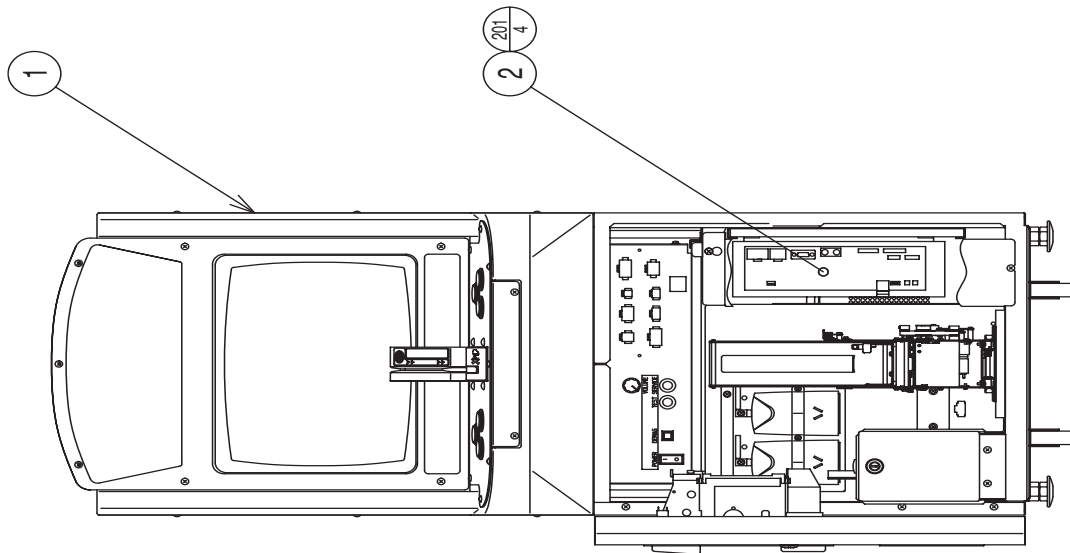
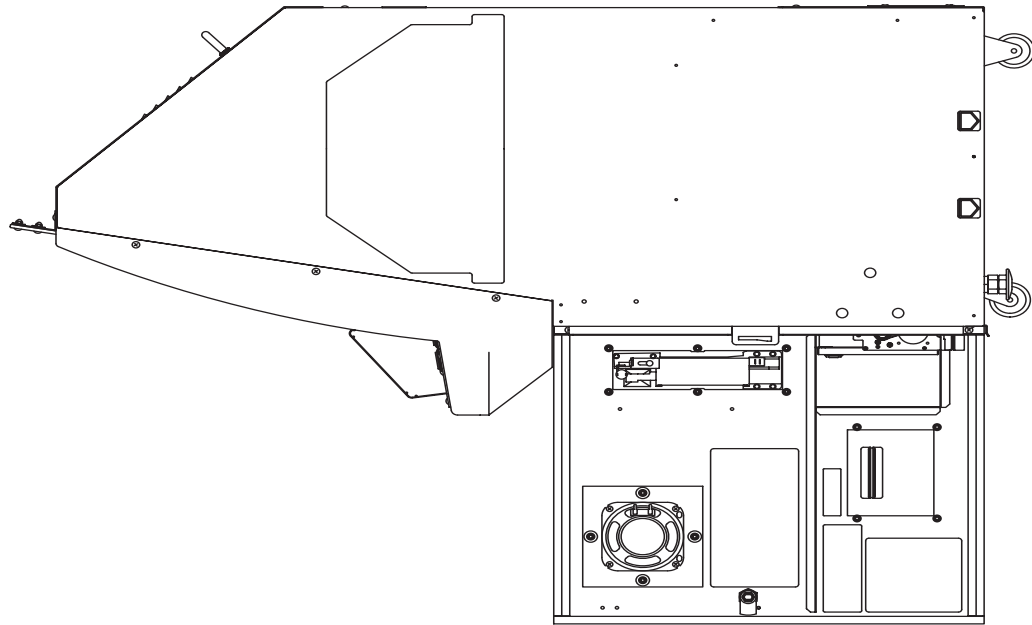

HARD CANDY
 WWW.HARD-CANDY.COM キャンディ
 ハード

ITEM NO.	PART NO.	DESCRIPTION	NOTE
1	MKC-0000-01	TOP ASSY MKC EXP CABI OEM	
2	840-0150D-02	ASSY CASE NAO MKG 2K3 2ND EXP	OTHERS
	840-0150D-04	ASSY CASE NAO MKG 2K3 2ND AUS	AUSTRALIA
201	000-P00412-W	M SCR PH W/FS M4X12	

(1) TOP ASSY MKC EXP CABI OEM (MKC-0000-01) (1/3)

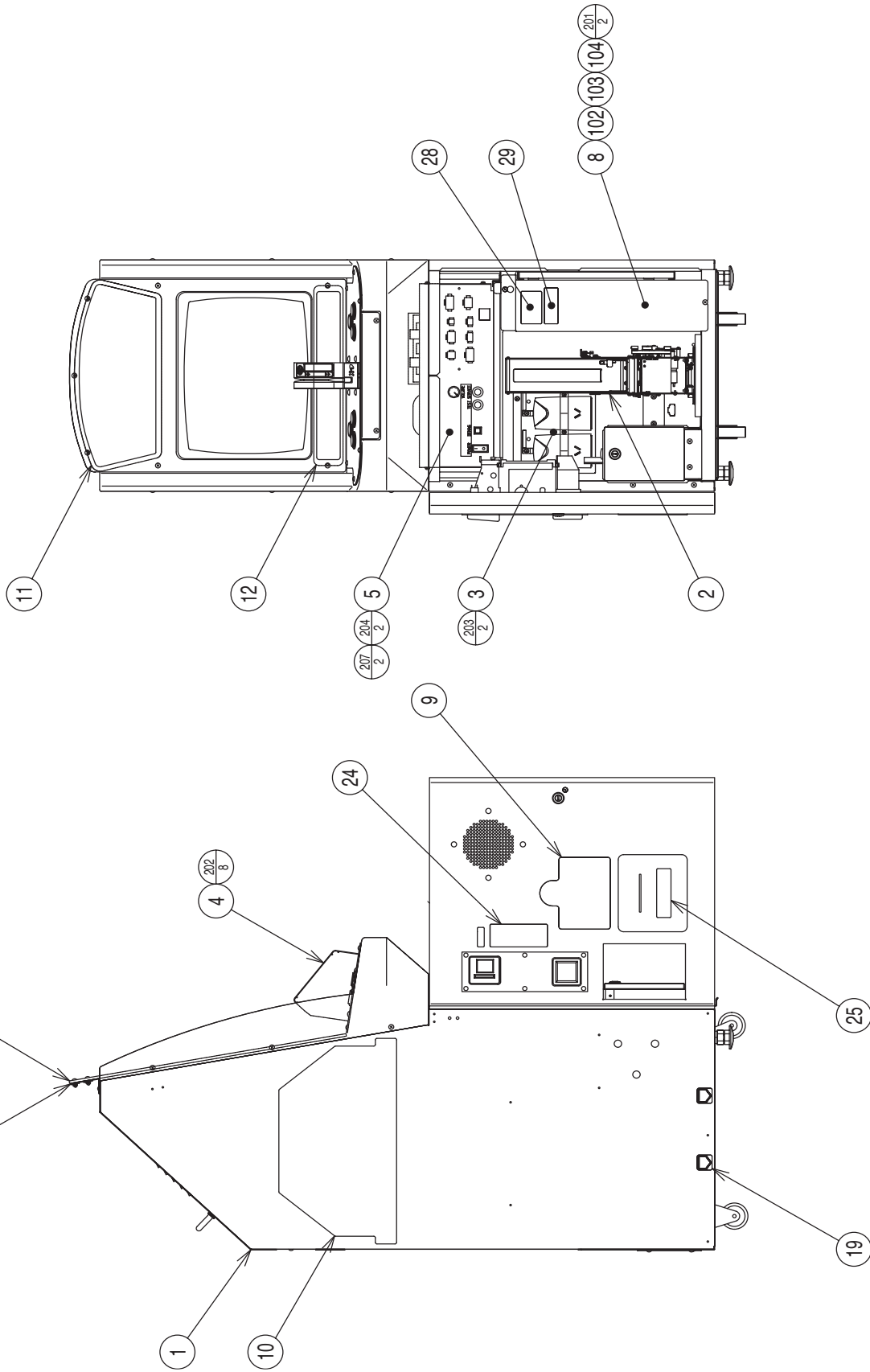

20
PARTS LIST

(1) TOP ASSY MKC EXP CABI OEM (MKC-0000-01) (2/3)

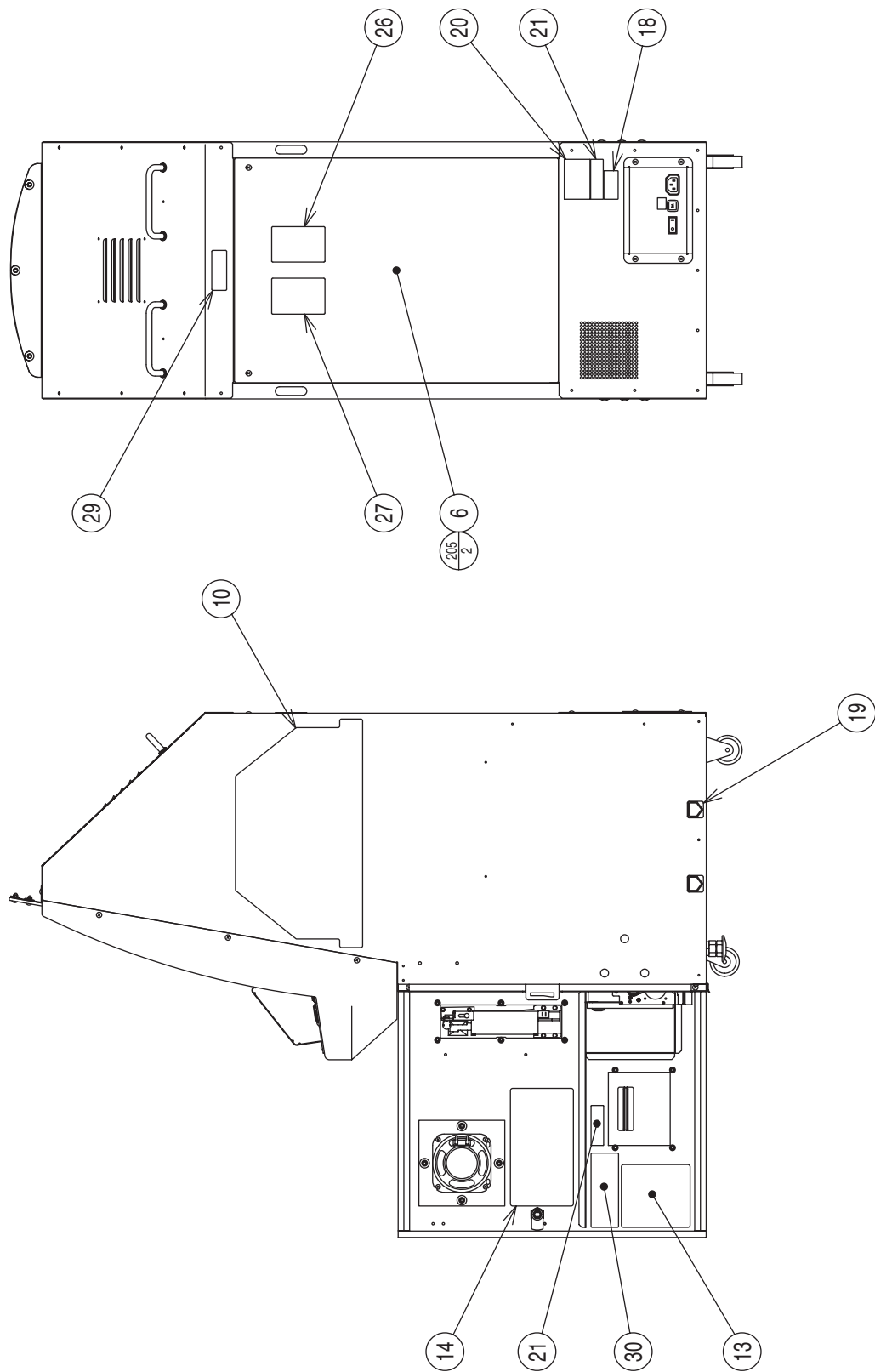

(1) TOP ASSY MKC EXP CABI OEM (MKC-0000-01) (3/3)

ITEM NO.	PART NO.	DESCRIPTION	NOTE
1	MKC-1000-01	ASSY CABINET MKC EXP	
2	MKG-0500-01	ASSY CARD DISPENSER EXP	
3	MKG-0600	ASSY RFID CHIP R/W	
4	MKC-2000-01	ASSY CTRL PANEL MKC EXP	
5	MKC-4200-01	ASSY ELEC BASE MKC EXP	
6	MKC-0001	BACK LID MKC	
7	MKC-0002	BOARD BRKT MKC	
8	MKG-0004-01	NAOMI COVER EXP	
9	MKG-0005-01	STICKER PICOUT CARD ENG	
10	MKG-0006-01	STICKER CABI SIDE ENG	
11	MKG-0007-01	DISPLAY SHEET MUSHI ENG	
12	MKG-0008-01	PLAY INSTR SHEET MUSHI ENG	
13	MKG-0010-01	STICKER HOW TO SET CARD ENG	
14	MKG-0012-01X	STICKER HOW TO REMOVE CARD ENG	
15	MKG-0015-01	STICKER MANAGEMENT CP R/W ENG	
16	TOE-NMD110-CN	MONITOR COVER PLATE CN	
19	421-11416	STICKER CAUTION FORK	
22	421-8479-01	STICKER INSTR SUNLIGHT ENG	
24	440-CS0200-EG	STICKER C EPILEPSY MINI ENG	
25	440-CS0290-EG	STICKER C CARD PICOUT ENG	
26	440-WS0001XEG	STICKER W NOT OPEN DOOR ENG	
27	440-WS0002XEG	STICKER W POWER OFF ENG	
28	440-WS0215-EG	STICKER W BD POWER OFF S ENG	
29	440-WS0286-EG	STICKER W DO NOT OPEN ENG	
30	440-WS0291-EG	STICKER W DISPENSER ENG	
101	601-0460	PLASTIC TIE BELT 100MM	
102	601-6231-A025	EDGING NEW TYPE	
103	601-6231-A030	EDGING NEW TYPE	
104	601-6231-A050	EDGING NEW TYPE	
201	000-T00408-0C	M SCR TH CRM M4X8	
202	000-T00412-0C	M SCR TH CRM M4X12	
203	000-P00408-W	M SCR PH W/FS M4X8	
204	000-P00420-W	M SCR PH W/FS M4X20	
205	008-T00408-0C	TMP PRF SCR TH CRM M4X8	
206	050-C00400-3C	CAP NUT TYPE3 CRM M4	
207	068-441616	FLT WSHR 4.4-16X1.6	
208	068-441616-0C	FLT WSHR CRM 4.4-16X1.6	
401	MKC-0003	POP SUPPORT MKC	
402	MKC-0004-01	CABINET HOLD BRKT MKC EXP H58	
403	MKG-0009-01	POP MUSHI ENG	
404	MKG-0011-01	CLEANING CARD FOR CARD RDR ENG	
405	SGM-2675X	POLYETHYLENE BAG 240X370	
406	SGM-4111Y	KEY BAG	
407	220-5785	KEY MASTER FOR 220-5784	
408	420-6455-01	SERVICE MANUAL NAOMI ENG	
409	600-6664-02	WIRE HARN EARTH W/LUG M6	TAIWAN
410	600-6618	AC CABLE CONNECT TYPE FOR EXP	OTHER
	600-6619-01	AC CABLE CONNECT TYPE FOR UK	HONG KONG
(OR)	600-6729	AC CABLE CONNECT TYPE 15A	TAIWAN
(OR)	600-7228	AC CABLE CONNECT TYPE 15A	TAIWAN
411	601-6604-70	CARTON BOX 70	
412	280-5009-01	CORD CLAMP 21	
413	540-0006-01	WRENCH M4 TMP SCR	
414	000-T00414-0C	M SCR TH CRM M4X14	



(2) ASSY CARD DISPENSER EXP (MKG-0500-01)

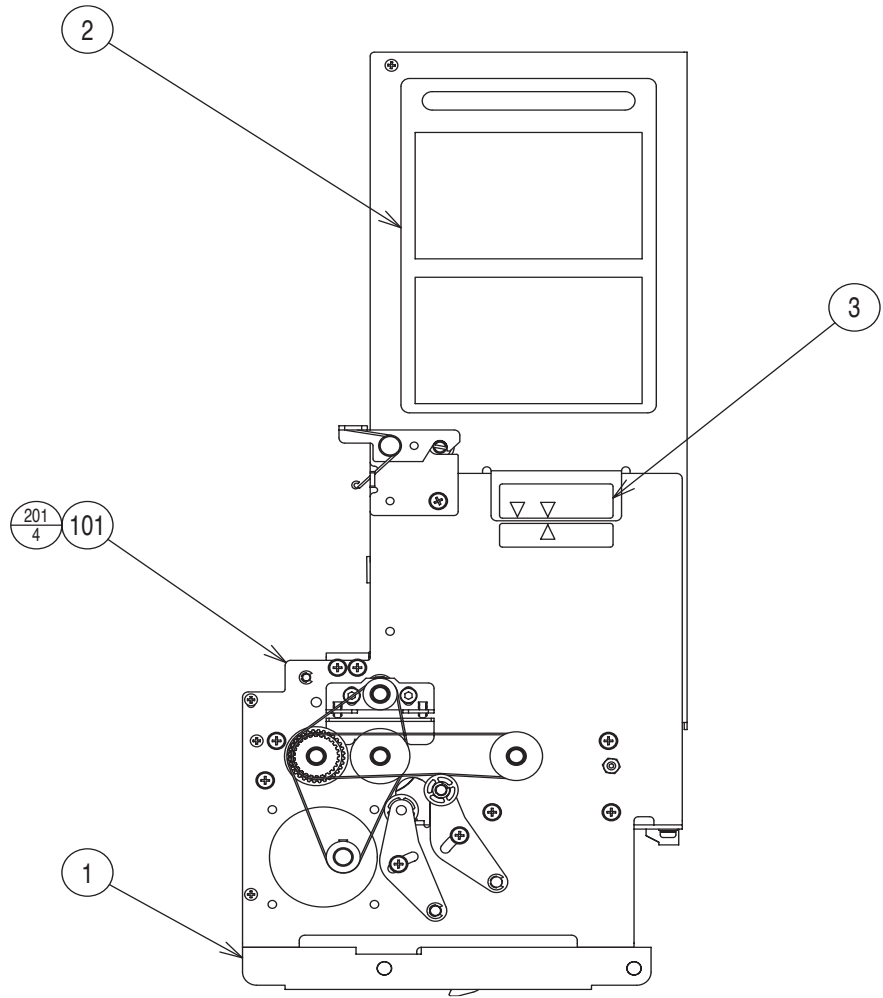
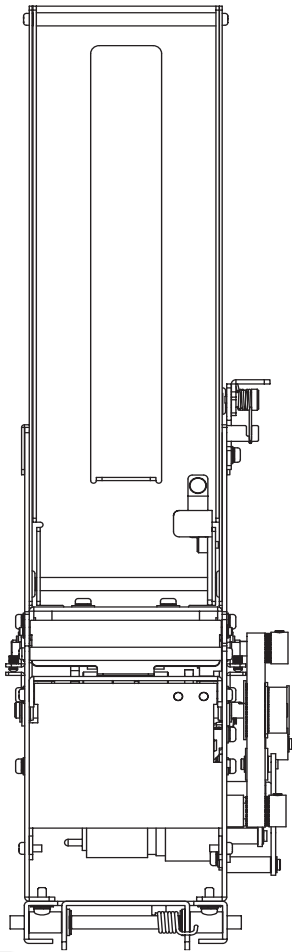

ITEM NO.	PART NO.	DESCRIPTION	NOTE
1	MKG-0550	ASSY SLIDER	
2	MKG-0501-01	STICKER HOW TO RMV STOCKER ENG	
3	MKG-0502	STICKER STOCKER POSITION	
101	610-0668-01	CARD DISPENSER CD-1300 ENG	
201	000-P00308-W	M SCR PH W/FS M3X8	
301	MKG-60001	WH CARD DISPENSER	

HARD CANDY
 WWW.HARD--CANDY.COM
 キャンディ
 ハード

(3) ASSY SLIDER (MKG-0550)

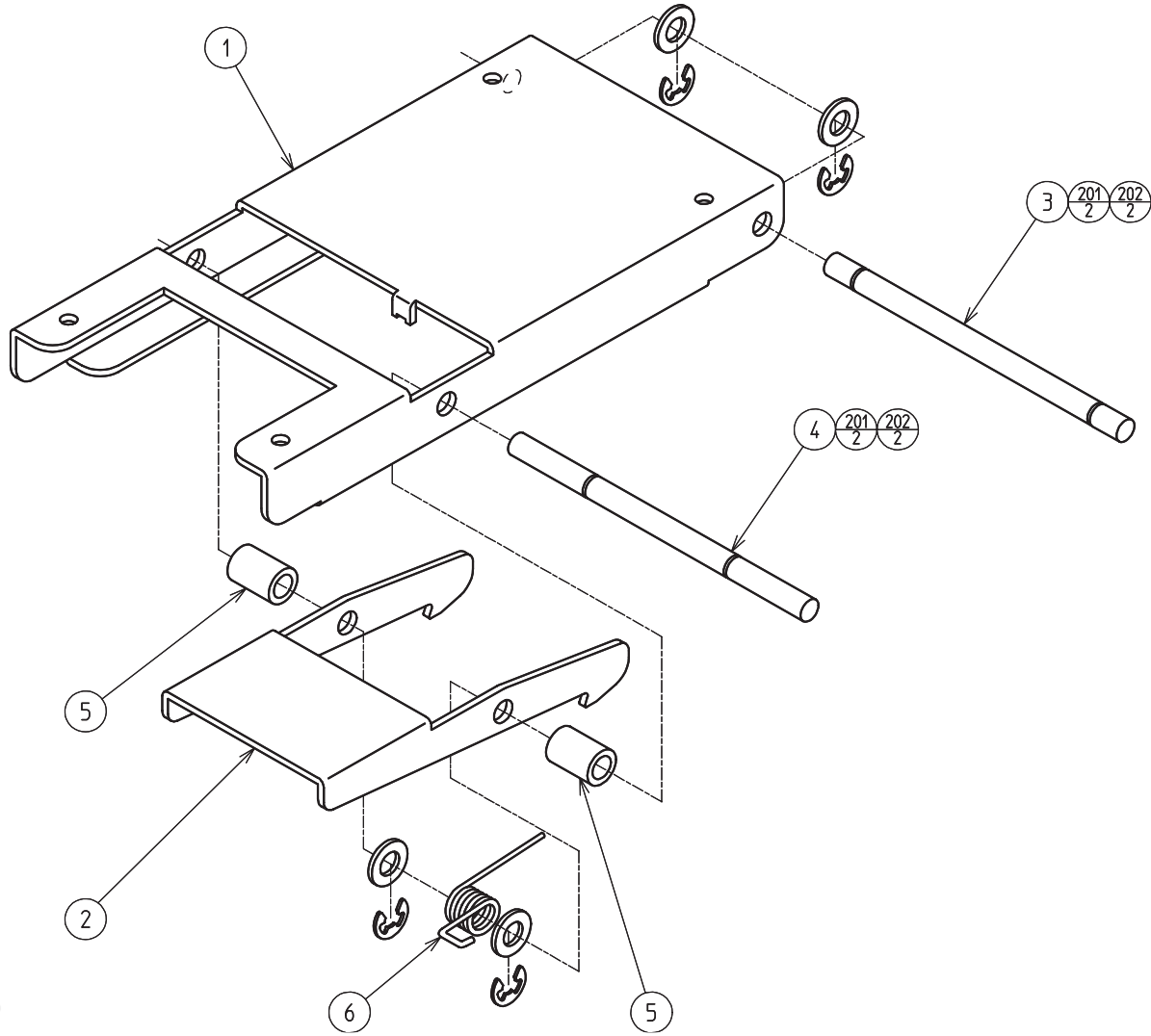

ITEM NO.	PART NO.	DESCRIPTION	NOTE
1	MKG-0551	CD BASE	
2	MKG-0552	STOPPER	
3	MKG-0553	SLIDE SHAFT	
4	MKG-0554	STOPPER SHAFT	
5	MKG-0555	SPACER	
6	MKG-0556	TORSION SPRING	
201	060-F00500	FLT WSHR M5	
202	065-E00400	E RING 4MM	

(4) ASSY RFID CHIP R/W (MKG-0600) (1/2)

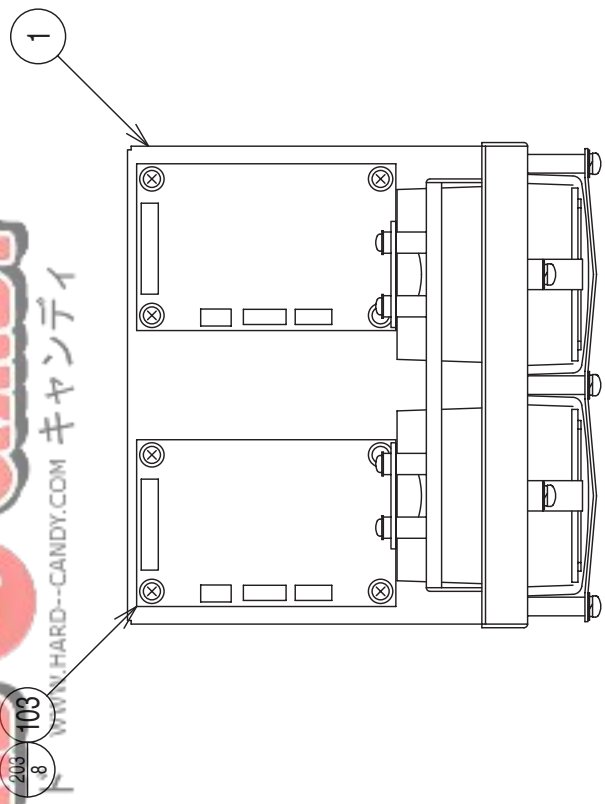

203
4 102

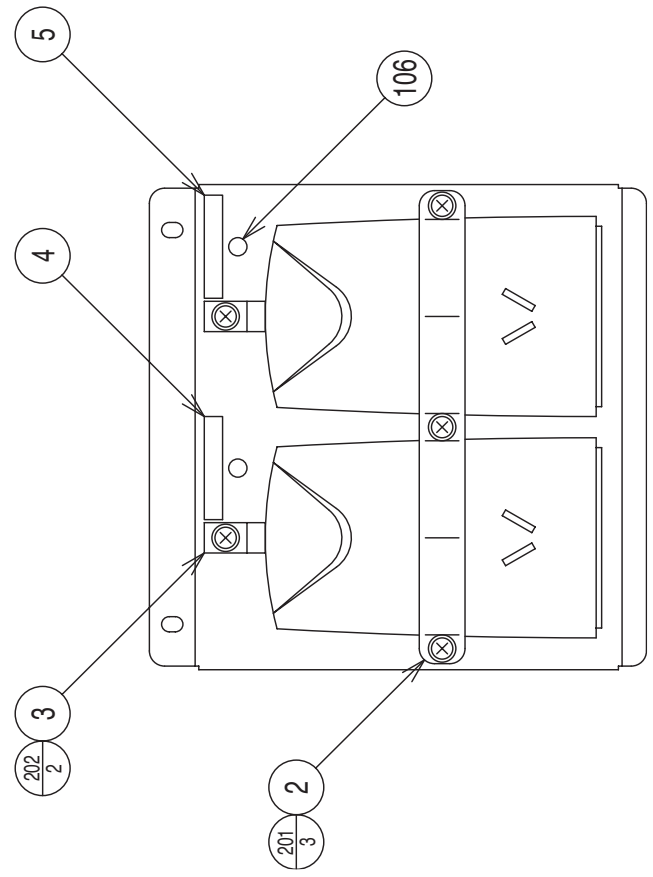
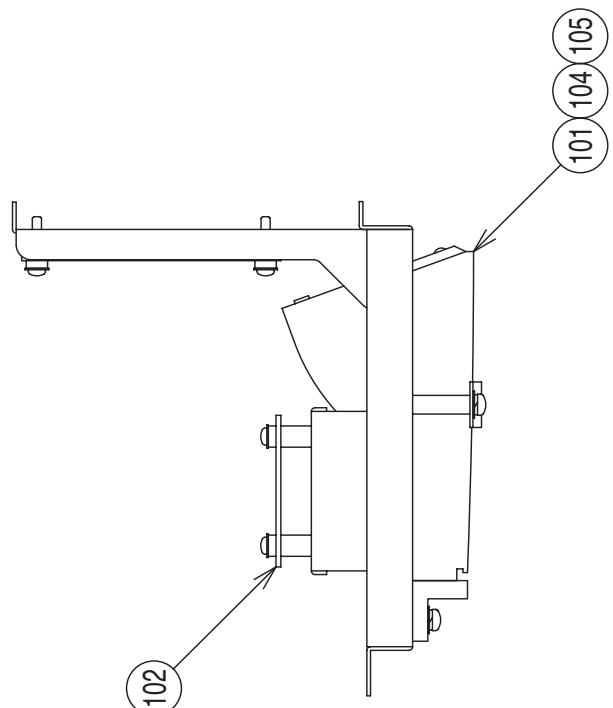

201
3 2

202
2 3

(4) ASSY RFID CHIP R/W (MKG-0600) (2/2)

ITEM NO.	PART NO.	DESCRIPTION	NOTE
1	MKG-0601	RFID CHIP R/W BRKT	
2	MKG-0602	RFID CHIP R/W STAY	
3	MKG-0603	RFID CHIP HOLDER	
4	MKG-0604	STICKER EMPTY LAMP1	
5	MKG-0605	STICKER EMPTY LAMP2	
101	838-14243	RFID CHIP R/W BD	
102	838-14244	RS232C I/F BD	
103	838-14245-92	MAPLE/232C CONVERT BD	
104	253-7207	RFID CHIP R/W COVER FRONT	
105	253-7208	RFID CHIP R/W COVER REAR	
106	390-6753	LED(DB-15-G)	
107	470-0151	RES 150 OHM 1/6W 5%	
108	280-5227	CORD CLAMP 18	
109	280-5275-SR10	CORD CLAMP SR10	
110	310-5029-B10	SUMITUBE F B 10MM	
111	310-5029-B20	SUMITUBE F B 20MM	
112	280-5247	ONE TOUCH BUSHING	
113	280-5248	ONE TOUCH COLLAR M3 L=10	
114	601-0460	PLASTIC TIE BELT 100MM	
201	000-P00308-W	M SCR PH W/FS M3X8	
202	000-P00412-W	M SCR PH W/FS M4X12	
203	010-P00320-F	S-TITE SCR PH W/F M3X20	
301	600-7265-02	WH SERIAL LINE	
302	MKG-60041	WH RFID CHIP CONTROL	
303	MKG-60042	WH EMPTY LAMP	
304	MKG-60043	WH EMPTY LAMP RES	



(5) ASSY CABINET MKC EXP (MKC-1000-01) (1/2)

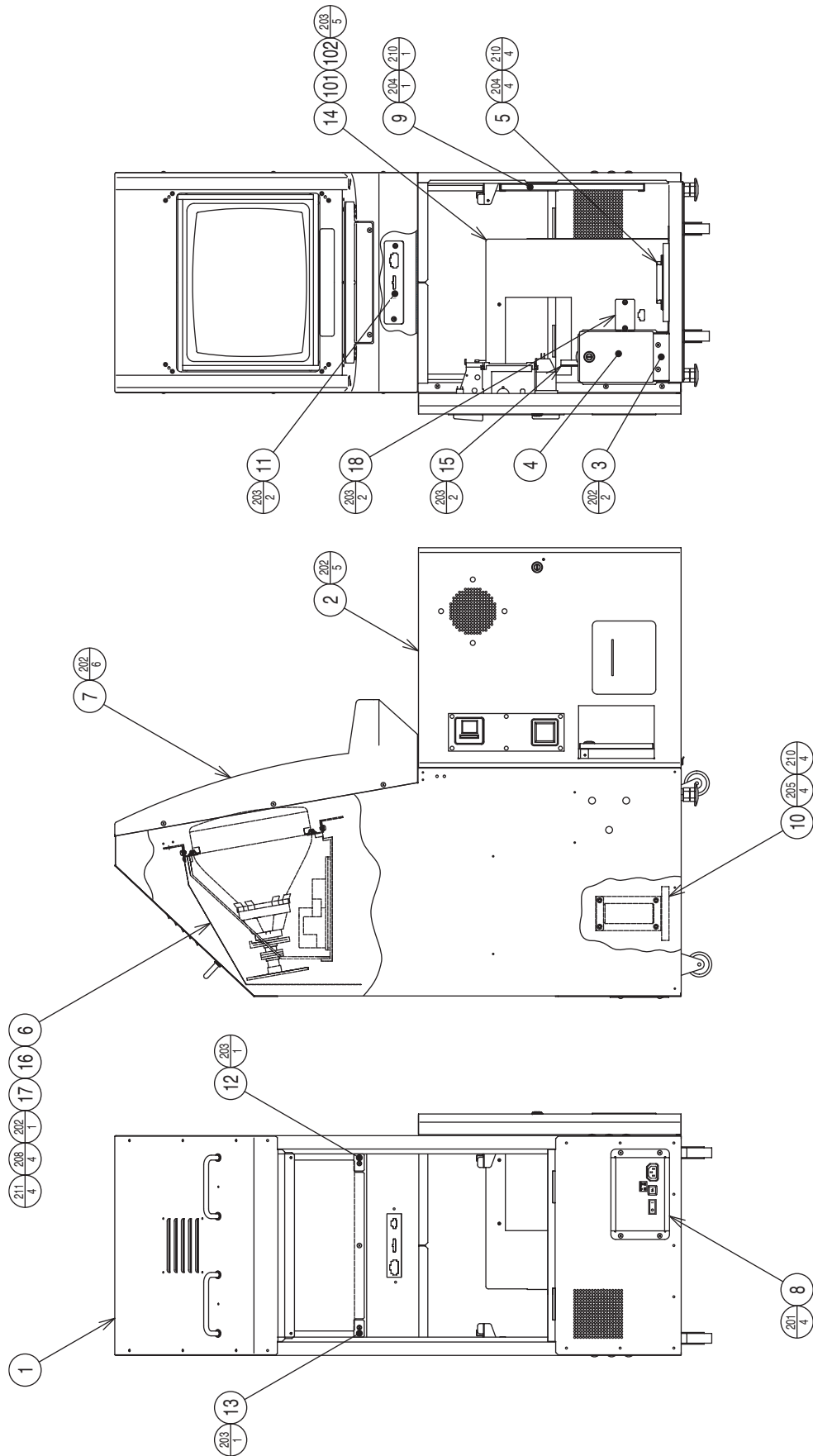

(5) ASSY CABINET MKC EXP (MKC-1000-01) (2/2)

ITEM NO.	PART NO.	DESCRIPTION	NOTE
1	MKC-1100-01	ASSY CABINET BLANK MKC EXP	
2	MKC-1200-01	ASSY DOOR MKC EXP	
3	MKG-1300-01	ASSY COUNTER BRKT EXP	
4	MKC-1400-01	ASSY CASH BOX MKC EXP	
5	MKC-1500-01	ASSY SLIDE BASE MKC EXP	
6	MKC-1600-01	ASSY MONITOR MKC EXP	
7	MKC-1700	ASSY FRONT MASK MKC	
8	999-2192	AC Unit Connector w/ fuse&switch	
9	MKC-4300-01	ASSY NAOMI BASE MKC EXP	
10	MKG-4400	ASSY XFMR	
11	999-219.3	PLATE CONN CTRL PANEL	
12	MKG-1002	PLATE CONN MONITOR AC	
13	MKG-1003	PLATE CONN MONITOR RGB	
14	MKG-1004-01	PARTITION EXP	
15	MKG-1005	COIN CHUTE EXP	
16	MKG-1006	BUSHING EXP	
17	MKG-1007	SPACER EXP	
18	MKG-1008	SEAL PLATE COUNTER	
101	601-6231-B-025	EDGING NEW TYPE	
102	601-6231-B-050	EDGING NEW TYPE	
103	601-6231-D-050	EDGING NEW TYPE	
104	280-5275-SR10	CORD CLAMP SR10	
105	280-5009-01	CORD CLAMP 21	
106	601-0460	PLASTIC TIE BELT 100MM	
201	000-T00408-0B	M SCR TH BLK M4X8	
202	000-T00408-0C	M SCR TH CRM M4X8	
203	000-P00408-W	M SCR PH W/FS M4X8	
204	000-P00420-W	M SCR PH W/FS M4X20	
205	000-P00425-W	M SCR PH W/FS M4X25	
206	031-000620-0C	CRG BLT CRM M6X20	
207	050-F00400	FLG NUT M4	
208	050-F00500	FLG NUT M5	
209	050-F00600	FLG NUT M6	
210	068-441616	FLT WSHR 4.4-16X1.6	
211	068-552016	FLT WSHR 5.5-20X1.6	
301	600-7187-1000	WIRE HARN VMS A 1000MM	
302	600-7188-1000	WIRE HARN VMS B 1000MM	
303	MKC-6001-01	ASSY WIRE CABINET DC EXP	
304	MKG-60002-01	WH AC INPUT EXP	
305	MKG-60003	WH MONITOR PWR	
306	MKG-60004-01	WH MONITOR D-SUB15P CN	OR
	MKG-60004	WH MONITOR D-SUB15P	OR
307	MKG-60037	WH EARTH AMP BASE	
308	MKG-60045	WH RFID CHIP PWR	



WWW.HARD-CANDY.COM

(6) ASSY CABINET BLANK MKC EXP (MKC-1100-01)

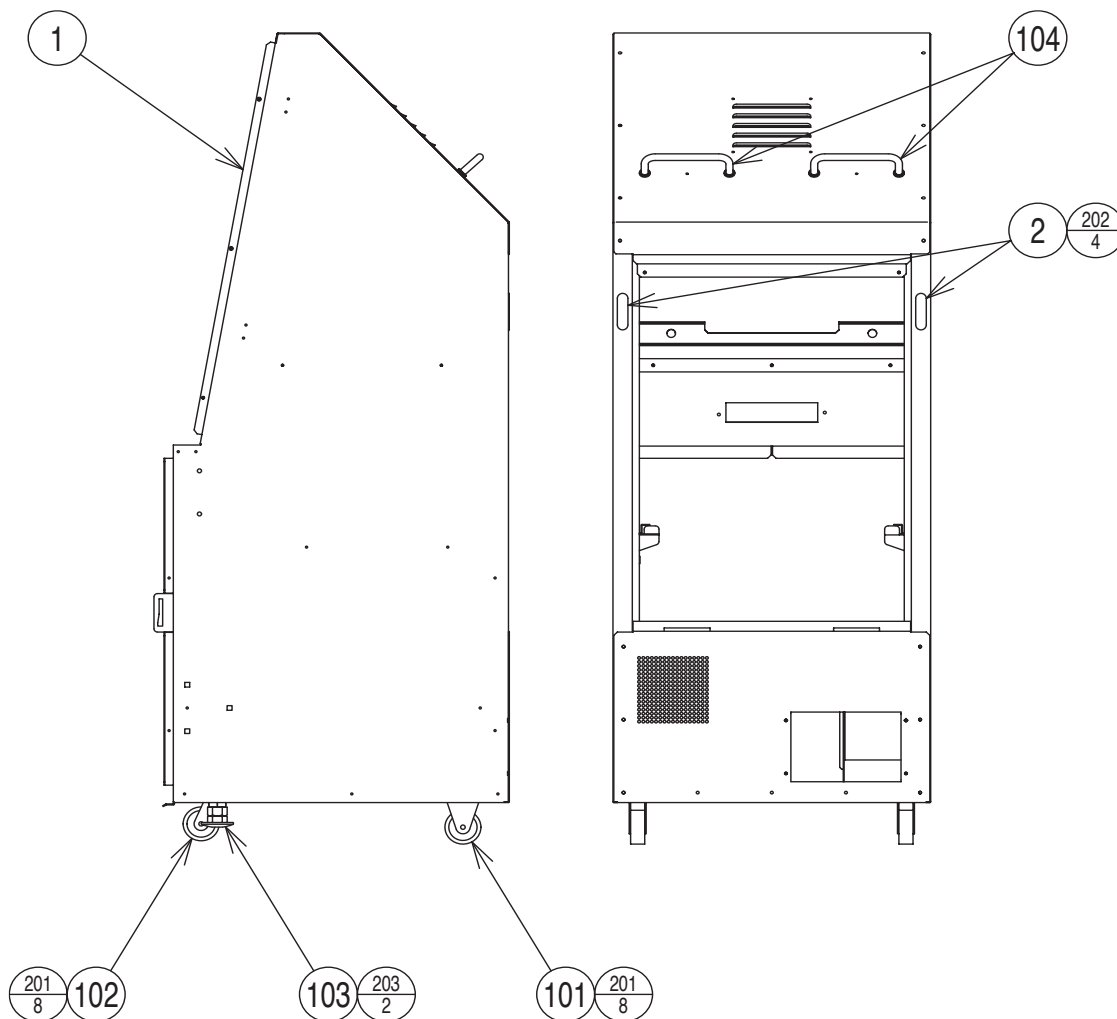

ITEM NO.	PART NO.	DESCRIPTION	NOTE
1	MKC-1101-01	CABINET BLANK MKC EXP	
2	999-2194	Chain Hooks	
101	601-10462	CASTER D51 H73 FIX	
102	601-10905	CASTER D51 H66 FREE ST	
103	601-5699X	LEG ADJUSTER BOLT M16X75	OR
	601-11384	LEG ADJUSTER BOLT M16X76	OR
104	TOE-NMD252	STAINLESS ROUND BAR PULLS	OR
	TOE-NMD252-CN	STAINLESS ROUND BAR PULLS CN	OR
201	030-000612-S	HEX BLT W/S M6X12	
202	050-F00400	FLG NUT M4	
203	050-H01600	HEX NUT M16	

(7) ASSY DOOR MKC EXP (MKC-1200-01)

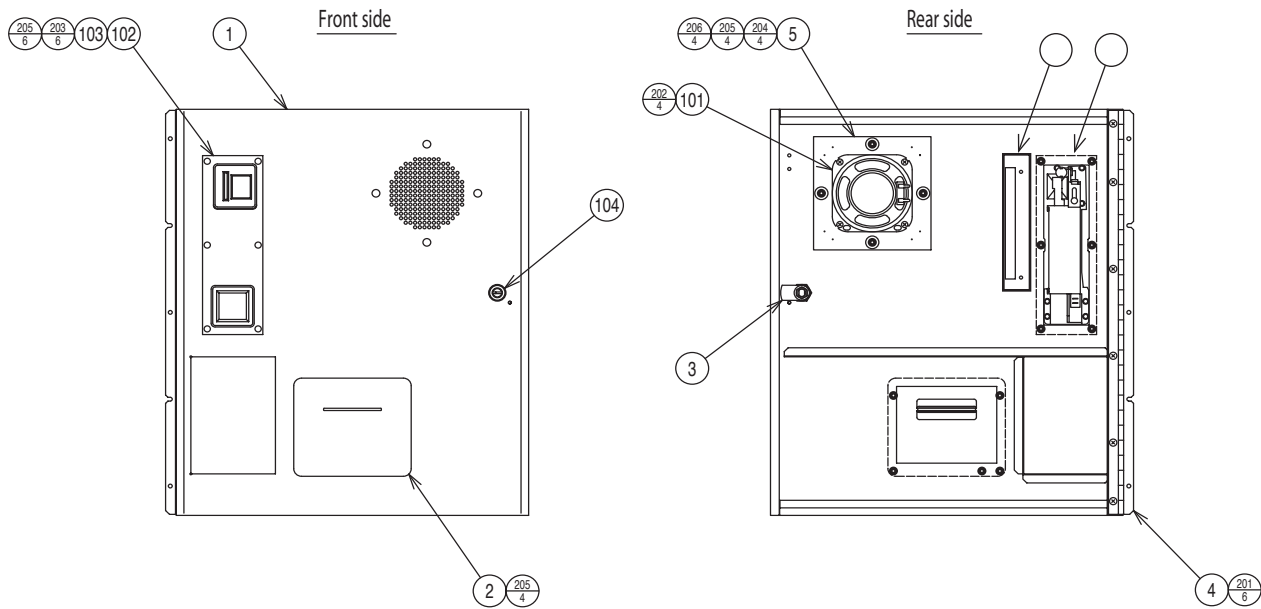

ITEM NO.	PART NO.	DESCRIPTION	NOTE
1	MKC-1201-01	DOOR MKC EXP	
2	MKG-1202	PICK OUT PLATE	
3	MKG-1203	TONGUE	OR
	MKC-1203	TONGUE MKC	OR
4	MKC-1204-01	HINGE MKC EXP	
5	MKG-1205	SPEAKER BASE WOODEN	
6	999-2195	Coin Comparator Control Board	(U.K. only)
7	999-2196	Coin Comparator	(U.K. only)
8	999-2197	Coin Mech	(U.S. only)
101	130-5034-03	SPEAKER 8 OHM 10W CN	OR
	130-5034	SPEAKER 8 OHM 10W	OR
102	220-5786	C.C BRKT A0710 (LORENZO)	
103	220-5208-96	COIN CHUTE REJR SINGAPORE \$1	SINGAPORE
	220-5208-29	COIN CHUTE REJR HONG KONG \$	HONG KONG
	220-5208-79	COIN CHUTE REJ TAIWAN ¥10	TAIWAN
	220-5208-83	COIN CHUTE REJR 10BAHT	THAILAND
104	220-5784	CAM LOCK MASTER W/O KEY EXP	
105	280-5227	CORD CLAMP 18	
106	280-5275-SR10	CORD CLAMP SR10	
107	601-0460	PLASTIC TIE BELT 100MM	
108	310-5379-06-370	SPIRAL TUBE KEP-6 L=370	
109	310-5029-D15	SUMI TUBE F D 15MM	
201	000-T00408-0C	M SCR TH CRM M4X8	
202	011-T03510	TAP SCR TH 3.5X10	
203	031-000410-0C	CRG BLT CRM M4X10	
204	031-000420-0C	CRG BLT CRM M4X20	
205	050-F00400	FLG NUT M4	
206	068-441616	FLT WSHR 4.4-16X1.6	
301	MKG-60013-01	WH DOOR EXP	
302	MKG-60034-01	WH EARTH DOOR EXP	
303	MKG-60047	WH SPEAKER	
304	MKG-60049	WH REJECT LAMP	



(8) ASSY COUNTER BRKT EXP (MKG-1300-01)

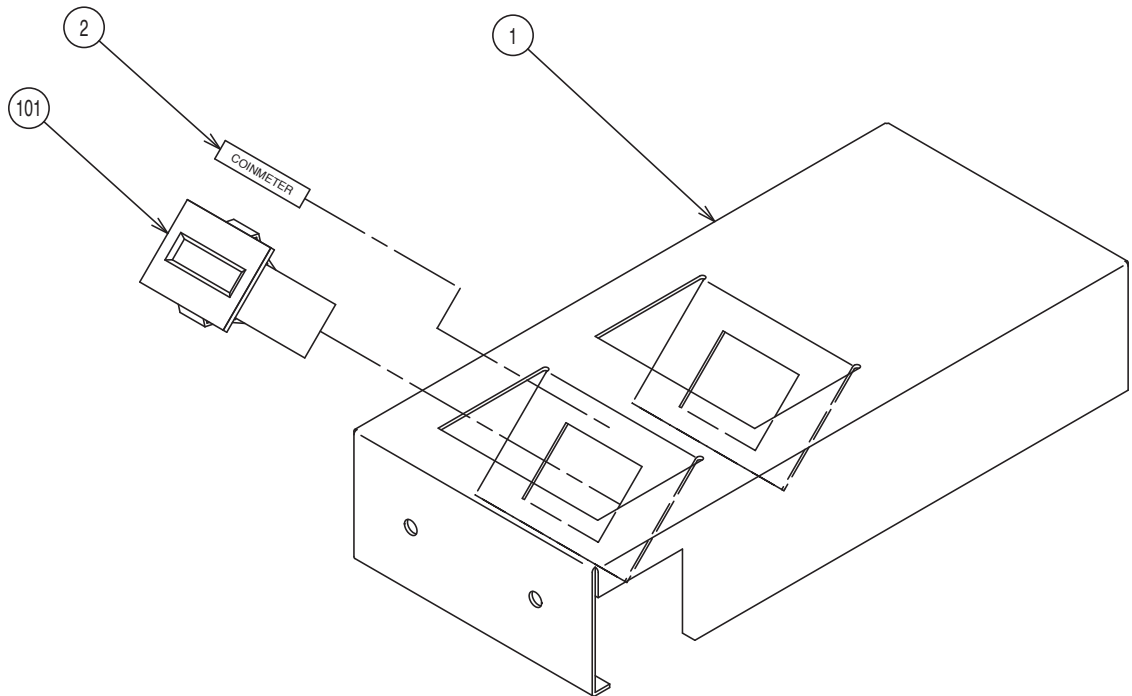

ITEM NO.	PART NO.	DESCRIPTION	NOTE
1	MKG-1301	COUNTER BRKT	
2	421-6591-01	STICKER COIN METER	
101	220-5643-01	MAG CNTR DC5V 6P WH	
102	280-5275-SR10	CORD CLAMP SR10	



(9) ASSY CASH BOX MKC EXP (MKC-1400-01)

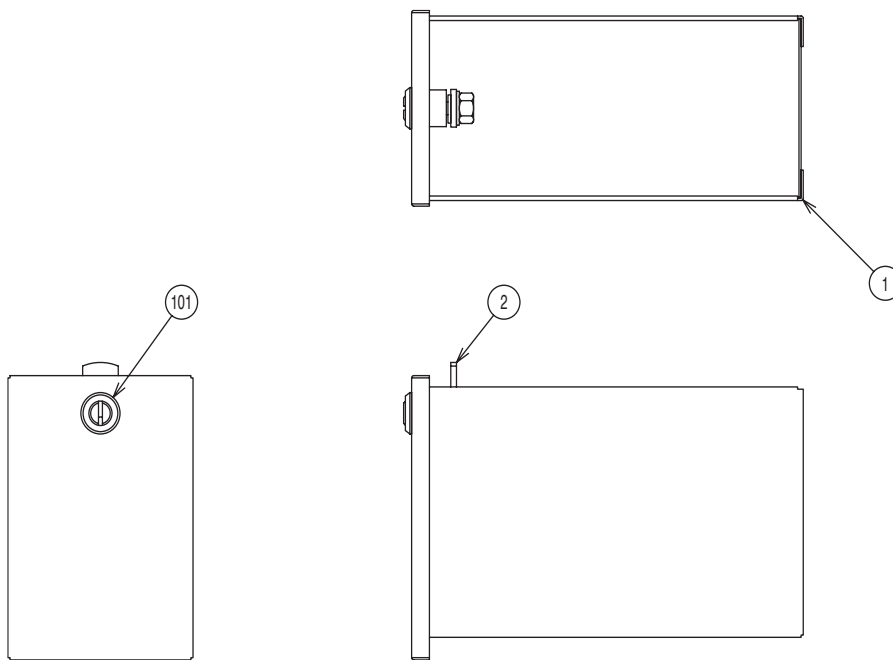

ITEM NO.	PART NO.	DESCRIPTION	NOTE
1	MKC-1401-01	CASH BOX MKC EXP	
2	MKG-1203	TONGUE	OR
	MKC-1203	TONGUE MKC	OR
101	220-5574	CAM LOCK W/KEYS	



(10) ASSY SLIDE BASE MKC EXP (MKC-1500-01) (1/2)

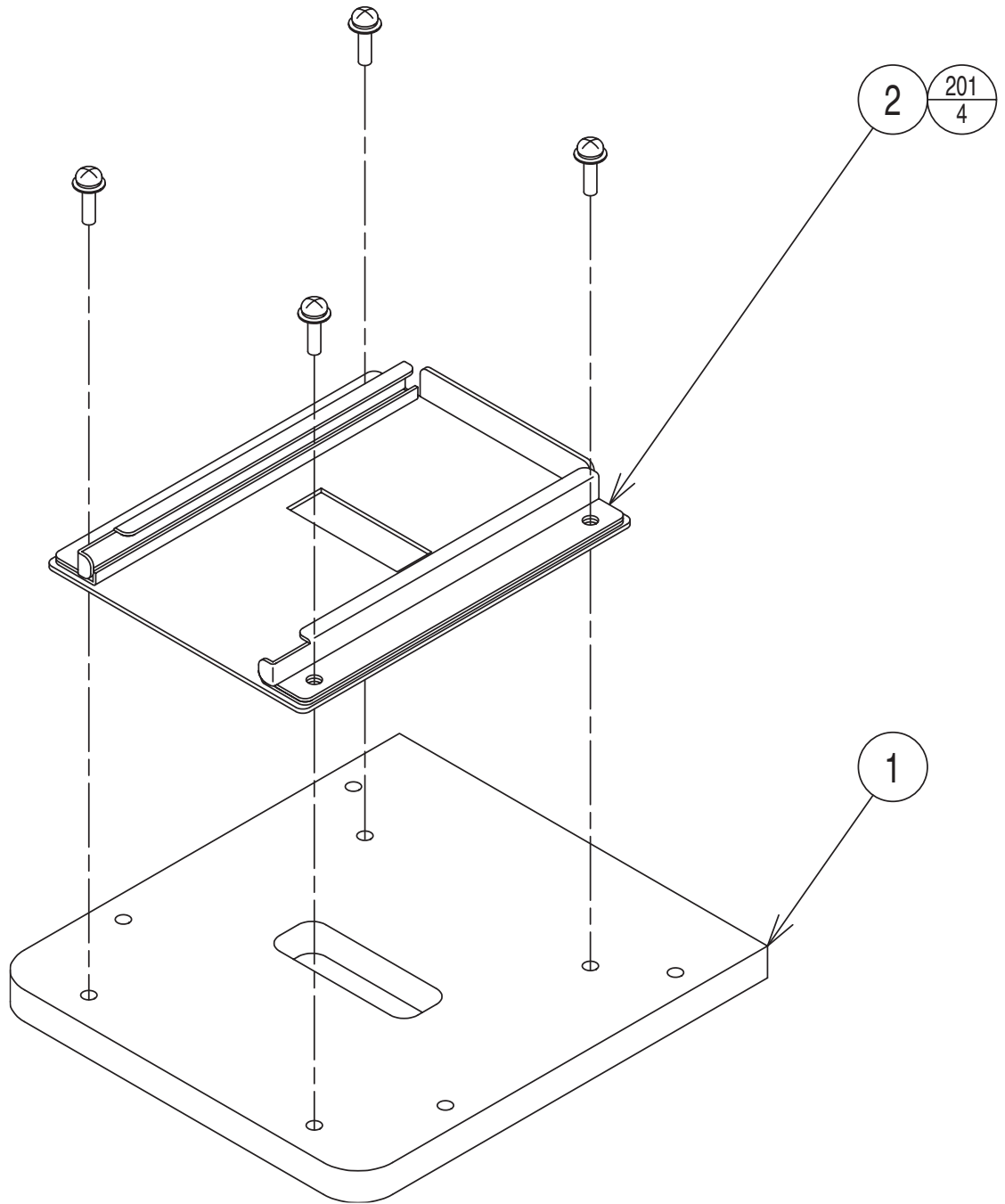

(10) ASSY SLIDE BASE MKC EXP (MKC-1500-01) (2/2)

ITEM NO.	PART NO.	DESCRIPTION	NOTE
1	MKG-1501-01	SLIDE BASE WOODEN CN	
2	MKG-1502	SLIDE BASE	
201	000-P00416-W	M SCR PH W/FS M4X16	



(11) ASSY MONITOR MKC EXP (MKC-1600-01) (1/2)

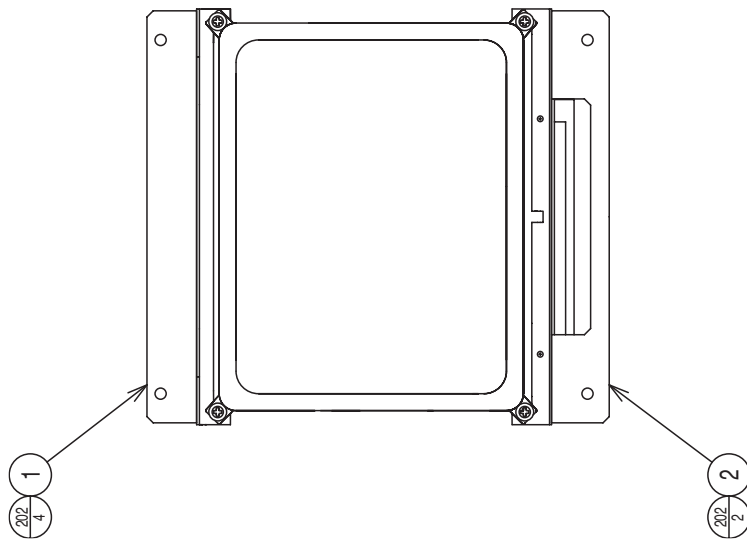
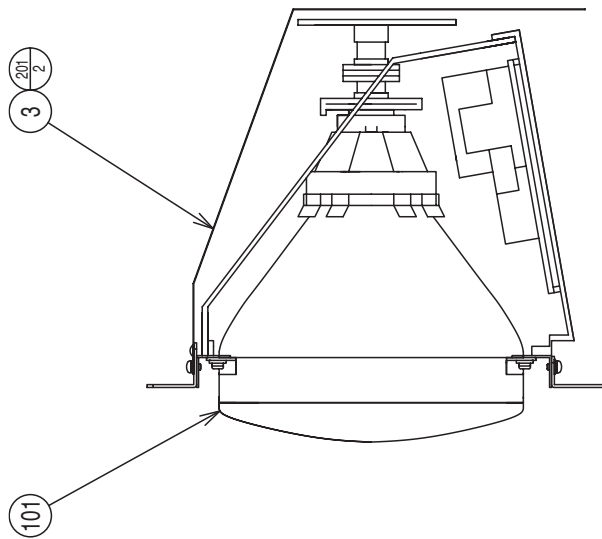
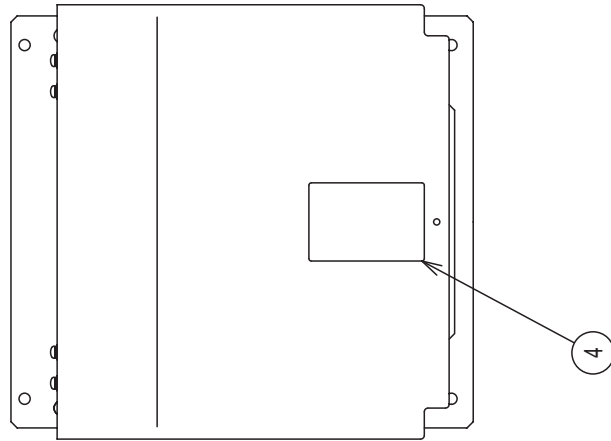

(11) ASSY MONITOR MKC EXP (MKC-1600-01) (2/2)

ITEM NO.	PART NO.	DESCRIPTION	NOTE
1	MKG-1601	MONITOR BRKT UPPER	OR
	MKC-1601	MONITOR BRKT UPPER MKC	OR
2	MKG-1602	MONITOR BRKT LOWER	OR
	MKC-1602	MONITOR BRKT LOWER MKC	OR
3	MKG-1603	MONITOR REAR COVER MKG	
4	440-DS0013XEG	STICKER D MONITOR ENG	
101	200-5173-15-03	CLR DSPL 14 15K100V 14VC21S HC	OR
	200-5173-15-04	CLR DSPL 14 15K100V 14VC21S HC	OR
102	601-0460	PLASTIC TIE BELT 100MM	
103	280-5275-SR10	CORD CLAMP SR10	
201	000-T00408-0C	M SCR TH CRM M4X8	
202	000-P00508-W	M SCR PH W/FS M5X8	



(12) ASSY FRONT MASK MKC (MKC-1700) (1/2)

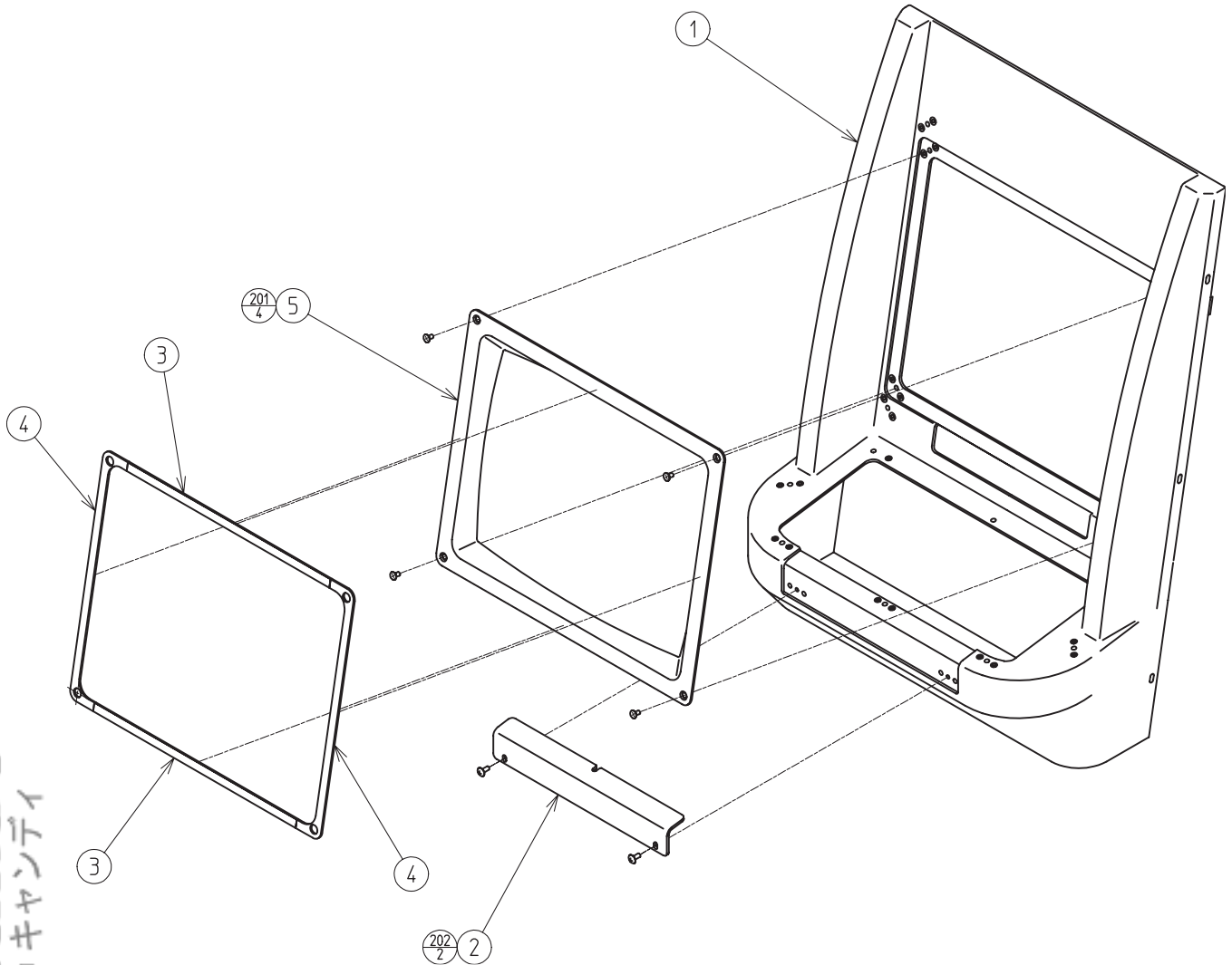

(12) ASSY FRONT MASK MKC (MKC-1700) (2/2)

ITEM NO.	PART NO.	DESCRIPTION	NOTE
1	MKG-1701-01	FRONT MASK CN	
2	MKC-1702	CTRL PANEL STAY MKC	
	MKG-1702	CTRL PANEL STAY	
3	MKG-1703	MONITOR SPONGE LONG MKG	
4	MKG-1704	MONITOR SPONGE SHORT MKG	
5	TOE-NMD105-CN	MONITOR MASK CN	
201	000-F00408	M SCR FH M4x8	
202	000-T00412-0C	M SCR TH CRM M4x12	



(14) ASSY NAOMI BASE MKC EXP (MKC-4300-01)

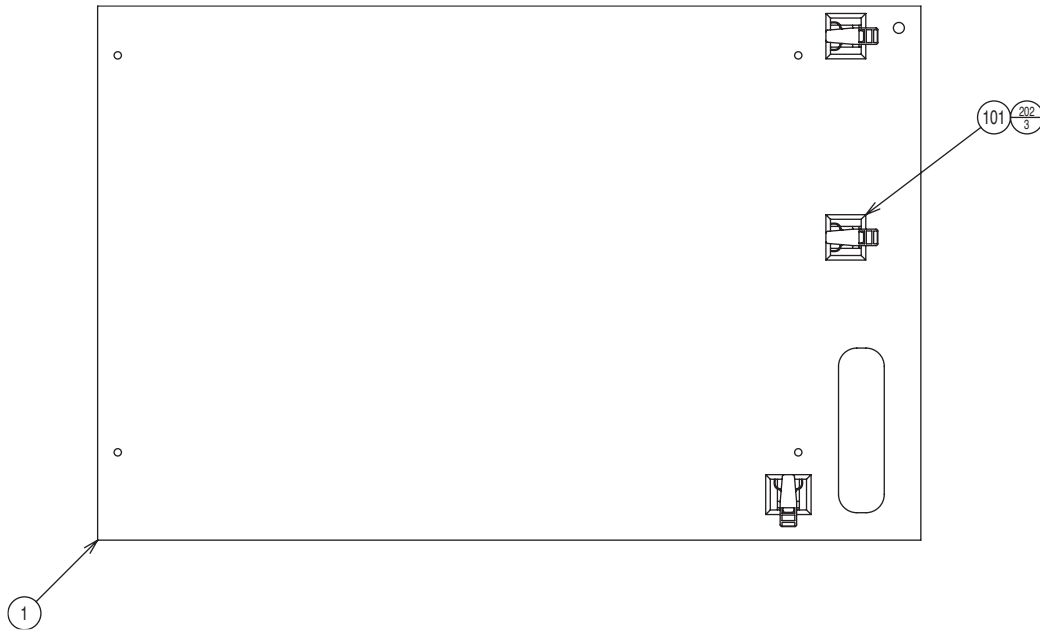

ITEM NO.	PART NO.	DESCRIPTION	NOTE
1	MKG-4301-01	NAOMI BASE WOODEN CN	
101	280-5277	CORD CLAMP 18	
202	011-F00312	TAP SCR FH 3X12	
301	600-7141-050	CABLE JVS TYPE A-B 050CM	
302	MKG-60007-01	WH JVS PWR VL8P EXP	
303	MKG-60008	WH JVS PWR VL6P	
304	MKG-60009	WH AUDIO NAOMI	
305	MKG-60010	WH SERIAL NAOMI	

(15) ASSY XFMR (MKG-4400)

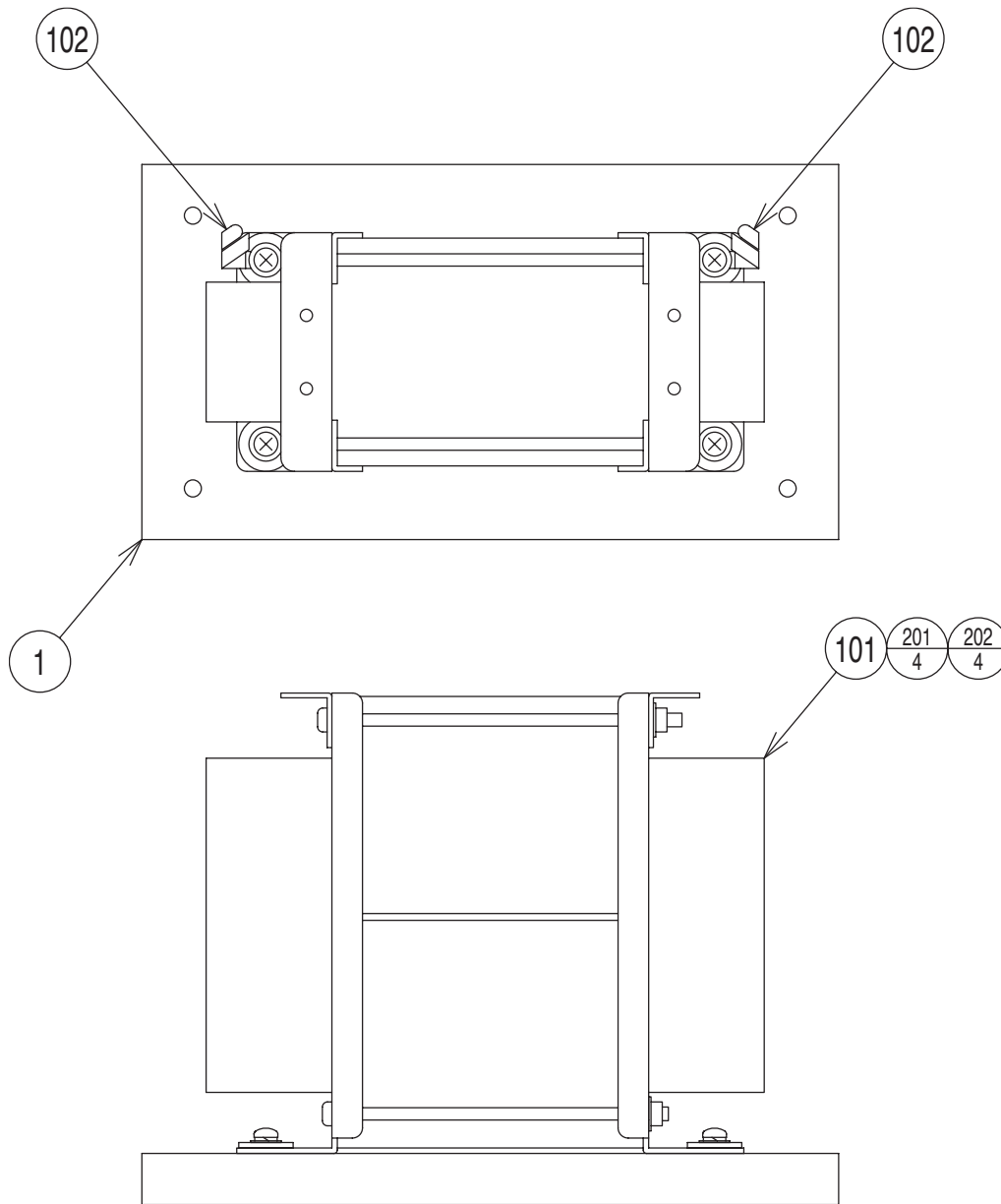

ITEM NO.	PART NO.	DESCRIPTION	NOTE
1	MKG-4401	XFMR BASE	
101	560-5516-V 560-5515-V	XFMR 220-240V 100V 5A WB CE XFMR 100-120V 100V 5A WB UL	AC 220-240V AREA AC 100-120V AREA
102	280-5207	HARNESS LUG CC-1005	
201	000-P00416-W	M SCR PH W/FS M4X16	
202	068-441616	FLT WSHR 4.4-16X1.6	



(16) ASSY WIRE CABINET DC EXP (MKG-6001-01)

This is comprised of the following wire harnesses. ASSY drawing is not available.

ITEM NO.	PART NO.	DESCRIPTION	NOTE
101	601-0460	PLASTIC TIE BELT 100MM	
301	MKG-60005-01	WH DOOR&CNTR EXT EXP	
302	MKG-60006-01	WH CARD DISPENSER EXT EXP	
303	MKG-60011	WH CARD READER	
304	MKG-60012	WH CTRL PANEL EXT	
305	MKG-60033-01	WH EARTH DOOR EXT EXP	
306	MKG-60035-01	WH EARTH CTRL PANEL	



(17) ASSY CTRL PANEL MKC EXP (MKC-2000-01)

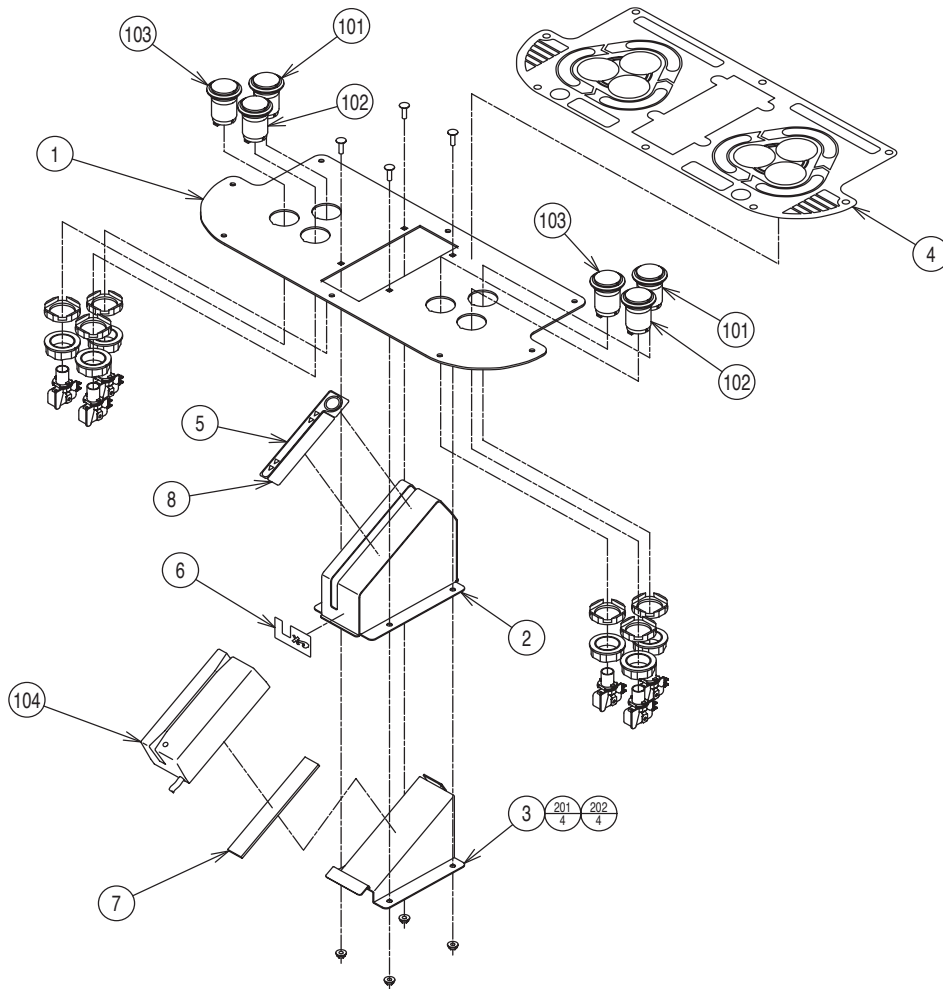

ITEM NO.	PART NO.	DESCRIPTION	NOTE
1	MKC-2001	CTRL PANEL PLATE MKC	
2	MKG-2002	CARD READER COVER	
3	MKG-2003	CARD READER BRKT	
4	MKG-2004-02	STICKER CTRL PANEL MUSHI ENG	
5	MKG-2005-01	STICKER BARCODE RDR CASE ENG	
6	MKG-2006-01	STICKER BARCODE READER CS ENG	
7	MKG-2007	CARD READER SUPPORT SPONGE	
8	MKG-2008-01	STICKER C BARCORD RDR CS ENG	
101	509-6025-R-01	SW PB OBSA-30UM W/O LP R GUU	
102	509-6025-B-01	SW PB OBSA-30UM W/O LP B PAR	
103	509-6025-Y-01	SW PB OBSA-30UM W/O LP Y CHO	
104	610-0669	BAR CODE READER MCR1111	
105	280-5277	CORD CLAMP 18	
106	601-0460	PLASTIC TIE BELT 100MM	
201	031-000412-0C	CRG BLT CRM M4X12	
202	050-F00400	FLG NUT M4	
301	MKG-60014	WH CTRL PANEL	
302	MKG-60036-01	WH EARTH CTRL PANEL EXP	



(18) ASSY ELEC BASE MKC EXP (MKC-4200-01) (1/3)

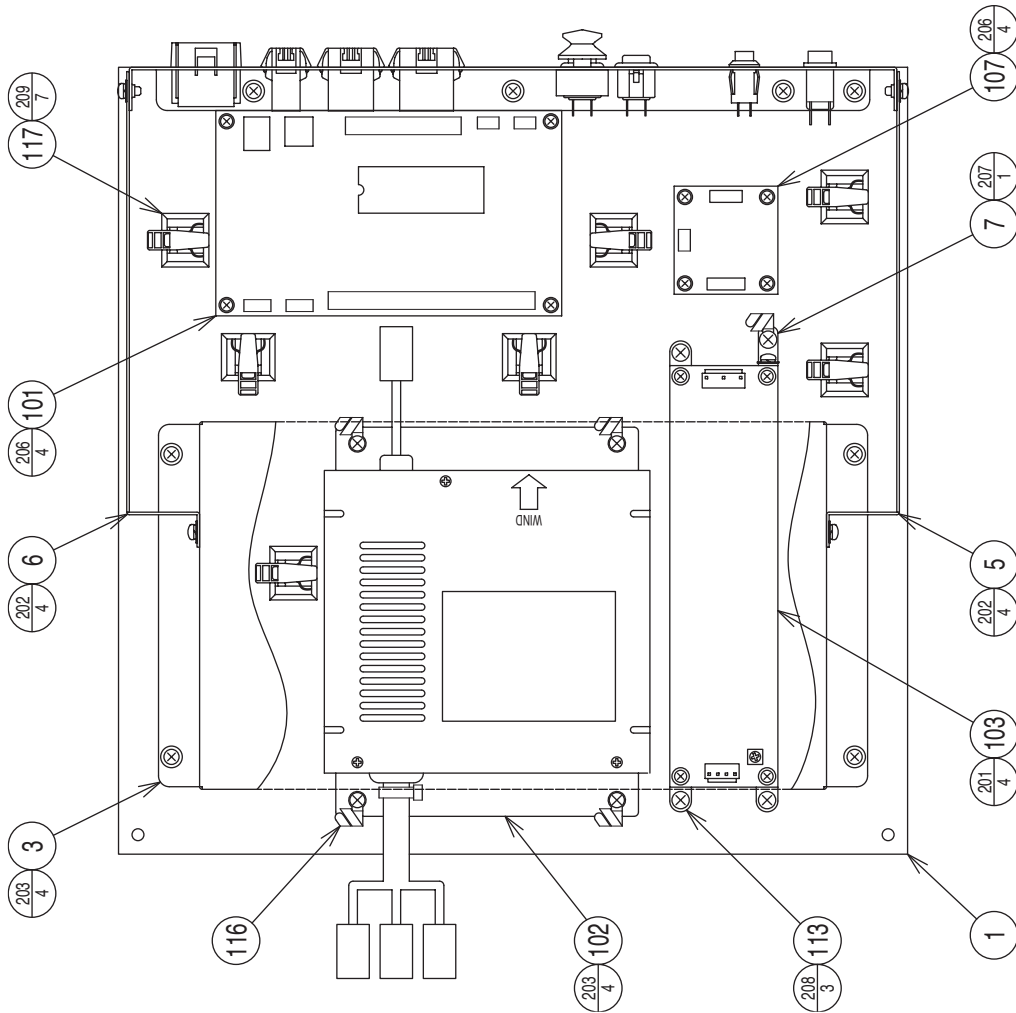
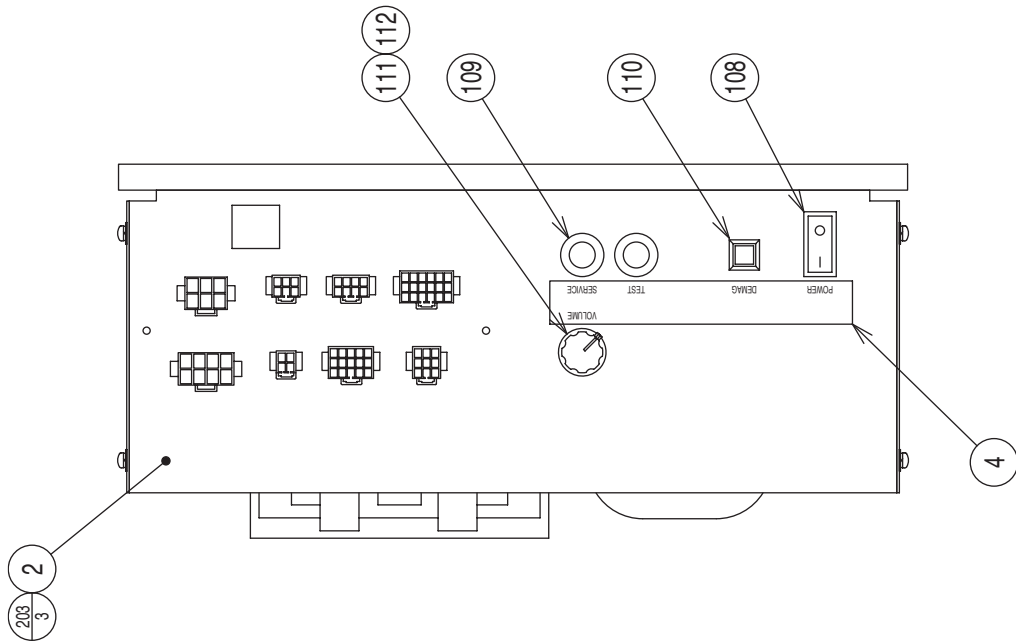

(18) ASSY ELEC BASE MKC EXP (MKC-4200-01) (2/3)

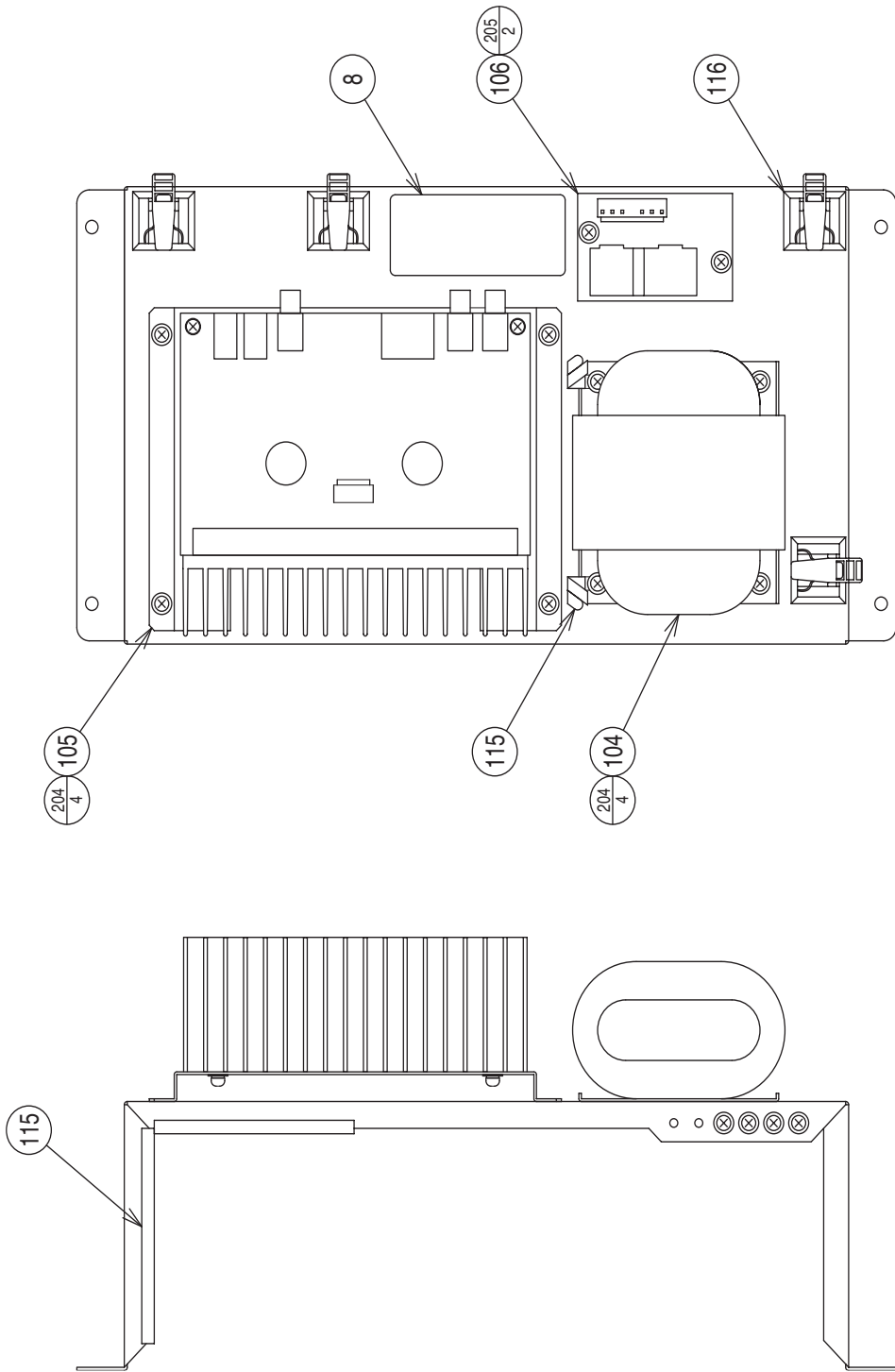

(18) ASSY ELEC BASE MKC EXP (MKC-4200-01) (3/3)

ITEM NO.	PART NO.	DESCRIPTION	NOTE
1	MKG-4201-02	ELEC BASE WOODEN CN EXP	
2	MKG-4202-01	SW&CONN PANEL EXP	
3	MKG-4203-01	AMP BASE EXP	
4	MKG-4204	STICKER SW&CONN PANEL	
5	MKG-4205	JOINT PLATE L	
6	MKG-4206	JOINT PLATE R	
7	MKG-4207	BD BRKT	
8	440-CS0282-EG	STICKER C FUSE REPLACEMENT ENG	
101	837-13551-92	I/O CONTROL BD FOR JVS	
102	400-5397	SW REGU FOR JVS	
103	400-5421-05024	SW REGU LCA50S-24	
104	560-5407	AUDIO XFMR 100V 17V2.1AX2	
105	838-13616	AUDIO POWER AMP 2CH	
106	838-11856-UL	CONNECT BD UL	
107	838-14361	SERIAL I/F BD MKG	
108	509-5453-V-B	SW ROCKER J8 V-B	
109	509-5875	SW PB (SINDEN SDP-103C)	
110	509-6055	SW PB SDP-103C-10RB (SHINDEN)	
111	220-5754	VOL CONT B5KOHM(RV24YN 15S)	
112	601-0042	KNOB 22MM	
113	601-7467	L LOCK BLACK	
114	310-5029-D15	SUMI TUBE F D 15MM	
115	601-6231-B-080	EDGING NEW TYPE	
116	280-5207	HARNESS LUG CC-1005	
117	280-5277	CORD CLAMP 18	
118	601-0460	PLASTIC TIE BELT 100MM	
201	000-P00306-W	M SCR PH W/FS M3X6	
202	000-P00408-W	M SCR PH W/FS M4X8	
203	000-P00412-W	M SCR PH W/FS M4X12	
204	010-P00306-F	S-TITE SCR PH W/F M3X6	
205	010-P00320-F	S-TITE SCR PH W/F M3X20	
206	011-P00325	TAP SCR PH 3X25	
207	011-T03512	TAP SCR TH 3.5X12	
208	011-T03516	TAP SCR TH 3.5X16	
209	011-F00312	TAP SCR FH 3X12	
301	MKG-60022	WH SUB SW IN	
302	MKG-60023	WH SUB SW OUT	
303	MKG-60024-01	WH CONN BD EXP	
304	MKG-60025	WH JVS PWR VL8P EXT	
305	MKG-60026	WH JVS PWR VL6P EXT	
306	MKG-60027	WH I/O BD PWR	
307	MKG-60028	WH AUDIO AMP	
308	MKG-60029	WH VOLUME	
309	MKG-60030	WH SERIAL BD IN	
310	MKG-60031	WH SERIAL BD OUT	
311	MKG-60032	WH JVS I/O RA60P	
312	MKG-60038	WH EARTH SW REGU FOR JVS	
313	MKG-60039	WH EARTH SW REGU LCA50S-24	
314	MKG-60040	WH EARTH SW&CONN PANEL	



21. WIRE COLOR CODE TABLE

THE WIRE COLOR CODE is as follow:

A	PINK
B	SKY BLUE
C	BROWN
D	PURPLE
E	LIGHT GREEN

Wires other than those of any of the above 5 single colors will be displayed by 2 alphanumeric characters.

1	RED
2	BLUE
3	YELLOW
4	GREEN
5	WHITE
7	ORANGE
8	BLACK
9	GRAY

If the right-hand side numeral of the code is 0, then the wire will be of a single color shown by the left-hand side numeral (see the above).

Note 1: If the right-hand side alphanumeric is not 0, that particular wire has a spiral color code.
The left-hand side character shows the base color and the right-hand side one, the spiral color.

<Example> 51 WHITE / RED

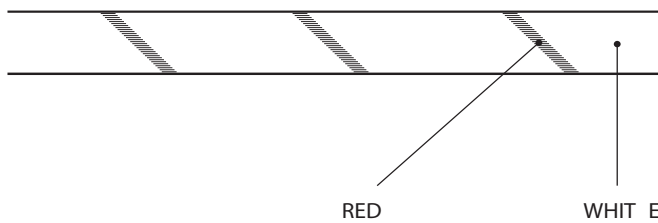

Note 2: The character following the wire color code indicates the size of the wire.

U:	AWG16
K:	AWG18
L:	AWG20
None:	AWG22





Warranty

Your new Sega Product is covered for a period of 90 days from the date of shipment. This certifies that the Printed Circuit Boards, Power Supplies and Monitor are to be free of defects in workmanship or materials under normal operating conditions. This also certifies that all Interactive Control Assemblies are to be free from defects in workmanship and materials under normal operating conditions. No other product in this machine is hereby covered.

Sellers sole liability in the event a warranted part described above fails shall be, at its option, to replace or repair the defective part during the warranty period. For Warranty claims, contact your Sega Distributor.

Should the Seller determine, by inspection that the product was caused by Accident, Misuse, Neglect, Alteration, Improper Repair, Installation or Testing, the warranty offered will be null and void.

Under no circumstances is the Seller responsible for any loss of profits, loss of use, or other damages.

This shall be the exclusive written Warranty of the original purchaser expressed in lieu of all other warranties expressed or implied. Under no circumstance shall it extend beyond the period of time listed above.



SEGA

SEGA AMUSEMENTS USA, INC.

45133 Industrial Drive
Fremont, CA 94538
(415) 701-6580 phone
(415) 701-6594 fax